



Nectre N60

Installation Instructions



Keep these instructions for future reference



Glen Dimplex Australia proudly supports the activities of Landcare Australia through its membership of the AHHA

Revision A

THE INSTALLATION INSTRUCTIONS IN THIS MANUAL APPLY TO THE NECTRE N60.

IT HAS BEEN TESTED FOR EMISSIONS AND EFFICIENCY AND COMPLIES ACCORDING TO AS/NZS 4012:2014 & AS/NZS 4013:2014.

1. IMPORTANT INFORMATION

Most building regulatory Authorities in Australia require any wood heater installation to comply with Installation Standard AS/NZS 2918:2018. Different states and councils may have varying regulations. Check local building regulations before installing the appliance.

All Nectre wood heaters have been tested to ensure that they will meet the appropriate safety Standard requirements if the instructions in this manual are followed. As the safety and emissions performance can be affected by altering the appliance, no modifications are allowed without written permission from the manufacturer.

WE RECOMMEND THAT THE INSTALLATION OF YOUR NECTRE WOOD HEATER BE CARRIED OUT BY A QUALIFIED INSTALLER.

WARNING: THE APPLIANCE AND FLUE SYSTEM SHALL BE INSTALLED IN ACCORDANCE WITH AS/NZS 2918:2018 AND THE APPROPRIATE REQUIREMENTS OF THE RELEVANT BUILDING CODE OR CODES.

WARNING: APPLIANCES INSTALLED IN ACCORDANCE WITH THIS STANDARD SHALL COMPLY WITH THE REQUIREMENTS OF AS/NZS 4012 & AS/NZS 4013 WHERE REQUIRED BY THE REGULATORY AUTHORITY, I.E. THE APPLIANCE SHALL BE IDENTIFIABLE BY A COMPLIANCE PLATE WITH THE MARKING 'TESTED TO AS/NZS 4012 & AS/NZS 4013'.

ANY MODIFICATION OF THE APPLIANCE THAT HAS NOT BEEN APPROVED IN WRITING BY THE TESTING AUTHORITY IS CONSIDERED TO BE IN BREACH OF THE APPROVAL GRANTED FOR COMPLIANCE WITH AS/NZS 4012 & AS/NZS 4013.

CAUTION: MIXING OF APPLIANCE OR FLUE-SYSTEM COMPONENTS FROM DIFFERENT SOURCES OR MODIFYING THE DIMENSIONAL SPECIFICATION OF COMPONENTS MAY RESULT IN HAZARDOUS CONDITIONS. WHERE SUCH ACTION IS CONSIDERED, THE MANUFACTURER SHOULD BE CONSULTED IN THE FIRST INSTANCE.

CAUTION: CRACKED AND BROKEN COMPONENTS, EG. GLASS PANELS OR CERAMIC TILES, MAY RENDER THE INSTALLATION UNSAFE.

2. COMPONENTS

Your Nectre N60 will arrive mainly fully assembled. The 8mm thick top plate and the pedestal glass insert will be packed in a cardboard box at the rear of the heater.

Inside the firebox are the following components:

- Firebricks – 4 bricks @ 270(h) x 175(w) x 25(d)mm & 2 bricks @ 270(h) x 85(w) x 25(d)mm
- Firebrick retainer
- Two 6mm thick steel baffle plates
- Ash pan
- Air slide handle
- Door handle extension
- Assorted bolts and spacers:
 - 2 screws @ M6 x 6mm
 - 2 washers @ M6
 - 4 firebox top spacers – 20.5mm x 19mm diameter tube
 - 4mm & 8mm Allen keys

IMPORTANT NOTE: The compliance plate on the rear of the heater is wrapped in plastic so as not to scratch the heater when in transit. Remove this plastic cover to avoid melting it when fire is lit.

3. ASSEMBLING THE HEATER

3.1 Assembling the Main Body

- a. Lay the firebox body down on its "back". Use a towel, rug, or the cardboard box it came in to avoid scratching the heater or the floor.
- b. Unscrew the four screws fixing firebox body to the pallet using a 5/16 hex socket and ratchet.
- c. Remove the square base cabinet from the box and position it so that the side with the four holes is adjacent to the base of the firebox body and the curved edge is at the top.

- d. Pass the M12 x 60mm screws from the inside through the four holes in the base cabinet.
- e. Slide a firebox bottom spacer (46mm x 19mm diameter) over each of the M12 screws.
- f. Thread the four M12 screws into the threaded holes in the base of the firebox.
- g. Before completely tightening the screws with the 8mm allen key, push the tube spacers out to the sides of the heater as far as possible and then tighten the screw. (The reason for this is so that the ash pan can slide more freely between the spacers.)
- h. With the base cabinet securely fastened to the firebox body, tilt the heater upright, and position it where it will be installed with the flue (Section 4. Installing the Heater).
- i. Place a firebox top spacer (20.5mm x 19mm diameter) over each of the vertical 12mm diameter rods on top of the firebox body.

3.2 Positioning the Top Plate

Remove the 8mm thick top plate from the box and place on top of the heater locating the hole in the plate over the flue spigot. Adjust the position of the top plate so that there is an even space between the top plate and the flue spigot.

3.3 Positioning the Ash pan

The ash pan can now be slid in to the gap created by the 46mm spacers between the firebox body and the base cabinet. This should slide all the way back, enough so that the door can then be closed.

4. INSTALLING THE HEATER

4.1 Positioning the Heater

First review the necessary clearances specified before considering where to position the heater.

Also check the practicability of installing the flue system in relation to any obstructing roof beams before positioning the heater.

These clearance distances can only be reduced if the surrounding walls are made of non-combustible material, eg. Stone, brick, or concrete. If non-combustible material, distance can be reduced to 100 mm. Alternatively, shielding of the wall(s) can reduce clearances (refer to next section for more detail).

Depending on the type of flue shielding used, the clearances to combustible surfaces varies.

4.1.1 Standard Installation:

Naked Model:

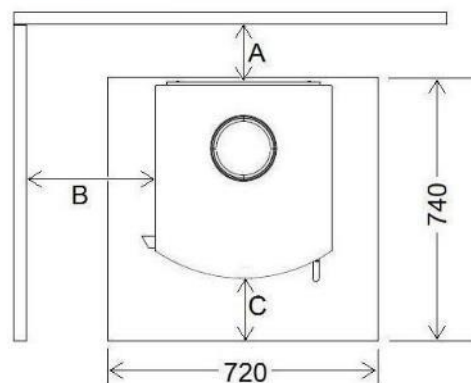

Curved Model:

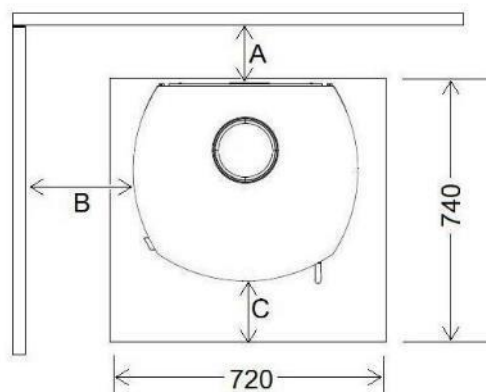

Tiled Sides Model:

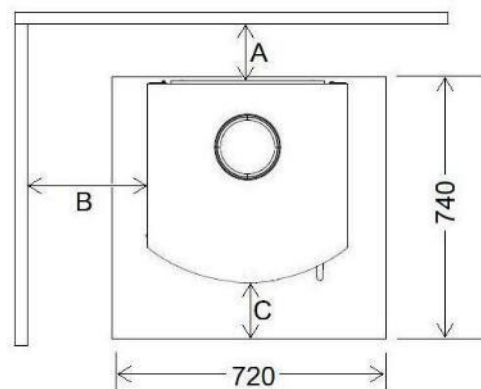

AS/NZS 2918:2018 Standard 6" flue kit

Fitted with 900mm stainless steel flue shield

N60 Model	A (mm)	B (mm)	C (mm)
Naked	75	450	250
Curved Sides	100	190	250
Tiled Sides	100	285	250

AS/NZS 2918:2018 Standard 6" flue kit

Fitted with Decromesh & 900mm stainless steel inner shield

N60 Model	A (mm)	B (mm)	C (mm)
Naked	125	450	250
Curved Sides	150	150	250
Tiled Sides	125	240	250

4.1.2 Corner Installation:

Naked Model:

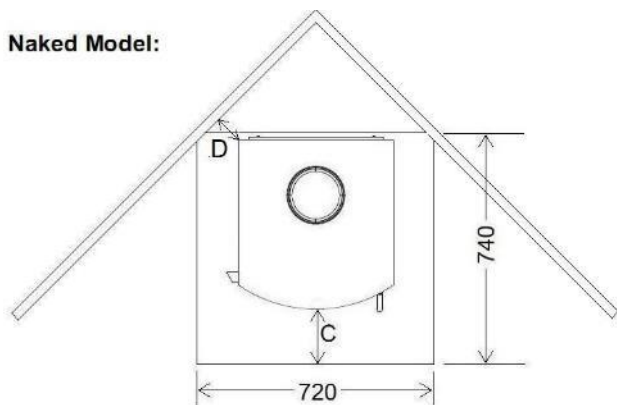

Curved Model:

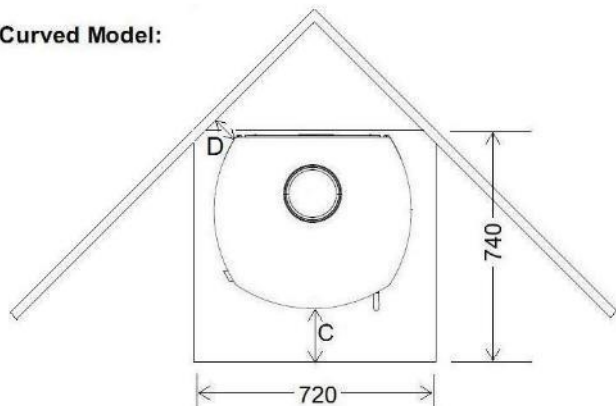

Tiled Sides Model:

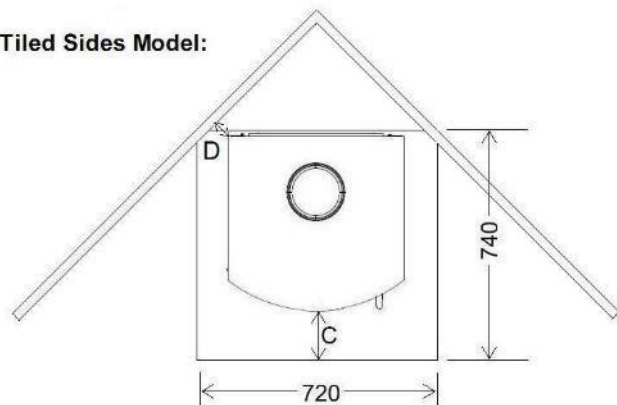

AS/NZS 2918:2018 Standard 6" flue kit

Fitted with 900mm stainless steel flue shield

N60 Model	C (mm)	D (mm)
Naked	250	225
Curved Sides	250	125
Tiled Sides	250	125

AS/NZS 2918:2018 Standard 6" flue kit

Fitted with Decromesh & 900mm stainless steel inner shield

N60 Model	C (mm)	D (mm)
Naked	250	225
Curved Sides	250	125
Tiled Sides	250	125

4.2 Floor Protector (Hearth)

Unless the heater will be standing on a heat resistant floor such as concrete slab with slate or tiles, it will be necessary to provide a floor protector (hearth).

The dimensions given in Section 4.1 are the minimum required for the floor protector. It must extend no less than 300 mm in front of the door opening (250mm from the curved front edge of the heater), no less than 200mm either side of the door opening, and extend under the heater.

The floor protector must be constructed from non-combustible material such as cement sheet or equivalent with a thermal conductivity not greater than 0.33W/m²K, the thickness of the floor protector must be no less than 7.5mm with minimum dimensions of 720mm wide x 740mm deep (extending from the rear of the heater to 250mm in front).

For more details and variations on floor protectors refer to AS/NZS 2918:2018 Clause 2.2, 3.3.1, & 3.3.2.

5. Reducing Clearances to Combustible Walls

If it is necessary to install a heater closer to a combustible surface than the stated requirements in Section 4 of this Installation Guide, it must be done in accordance with Australian Standard AS/NZS 2918:2018 Section 3, Tables 3.1 & 3.2.

Shield Construction:- The shield shall be constructed from a heat resistant material. The shield must be fixed to the surface that requires protection and NOT the heater.

The Standard allows three options to reduce stated clearances.

Single layer of continuous material with Minimum Air Gap of 12mm—Clearance Factor = 0.40

Single layer of continuous material with Minimum Air Gap of 25mm—Clearance Factor = 0.30

Two spaced layers of continuous material with Minimum Air Gaps of 12mm + 12mm—Clearance Factor = 0.20

The shielding must be open at the top and bottom (vented) to allow a continuous air flow. It is this air flow that keeps the surface requiring protection cool. Fixings should not impede this air flow.

The shielding needs to go far enough along and up the wall so that the original side and rear required clearances are not compromised. As the flue is now closer to the wall the shielding should also protect the wall from the flue pipe.

For example:

Side wall clearance for the N60 Naked is 450 mm.

A 12mm gapped shield on the wall with a factor of 0.40.

Calculate:- $450 \text{ mm} \times 0.40 = 180 \text{ mm}$. This is the new side wall minimum clearance.

The shielding needs to be large enough so that none of the original clearances of 450 mm are compromised.

6. INSTALLING THE FLUE

The flue system used when installing the heater MUST comply with the current installation standard AS/NZS 2918.

Full instructions on the installation of the flue will be supplied with the flue kit. These MUST be followed closely, including the minimum exit height from the top of the floor protector being not less than 4.6m, and the minimum exit height above the roof line of roof ridge as detailed in the instructions.

The flue must be fitted with either of the following:

- 1) Rear flue shield – 900 mm long, minimum 160° arc, stainless steel unpainted rear flue shield, OR
- 2) Decro-mesh – a full length, half radius perforated decro-mesh flue shield extending from the heater through into the drop box penetrating the ceiling. A 900 mm half round inner stainless steel reflector must be fitted inside the decro-mesh. Using tin-snips, cut 10mm tabs into the top and bottom of the inner reflector and bend out to create an air gap between it and the outer decro-mesh.

If the draft is insufficient or periodic down drafting occurs and the heater smokes or only burns slowly, extending the flue or fitting a specialised cowl will usually resolve the issue.

7. INSTALLING BAFFLE PLATES

The N60 is supplied with two baffle plates:-

- 1) Upper baffle plate – 300(w) x 200(d) x 6(h) mm.
 - Fit the upper baffle plate first.
 - Hold the baffle plate vertically at the rear of the firebox. Raise it up and over the upper front support lugs.
 - Slide it forward enough to clear the upper rear support lug, then slide it back so that the rear of the baffle plate is flush with the rear of the firebox.
 - Check that it is centralised, i.e. same size gap between baffle plate and sides of firebox.
- 2) Lower baffle plate – 360(w) x 260(d) x 6(h) mm
 - Hold the baffle plate vertically at the rear of the firebox with the slotted end at the bottom.
 - Raise it up and over the lower front support lugs.
 - Bring the front edge of the baffle plate as high and as far forward as possible, enough for the bottom rear edge to clear the lower rear support lugs.

- With baffle plate now resting on all four lower support lugs and pushed all the way back, the slots in the rear of the baffle plate should now line up with the air holes at the rear of the firebox.

Note: Bricks in the image below are to show perspective, the baffle plates need to be installed before the bricks go in.

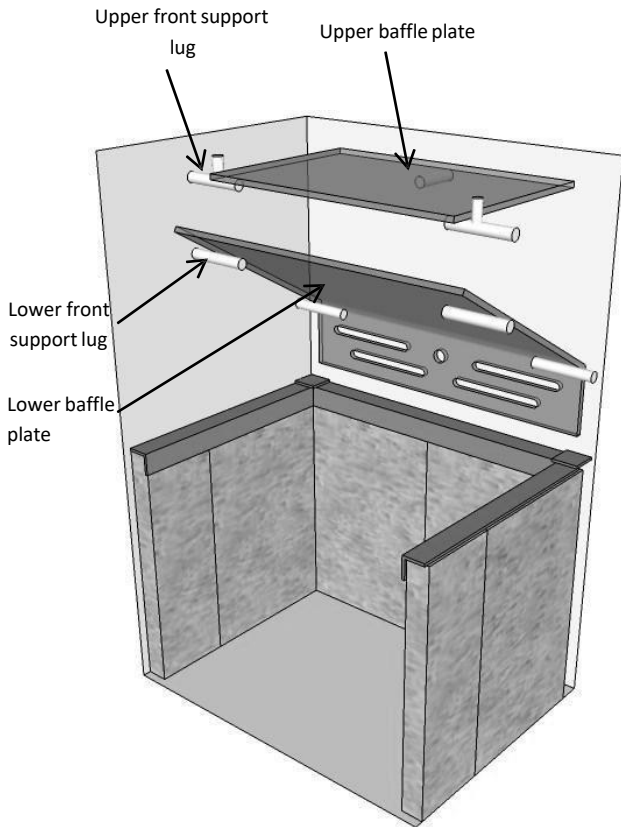

8. INSTALLING FIRE BRICKS

The N60 comes with 4 full size bricks (285(h) x 175(w) x 25(d)mm) and 2 half size bricks (285(h) x 85(w) x 25(d)mm).

Raise the brick retainer (supplied inside the firebox) and start standing the bricks up against the rear and sides of the firebox as shown in the following diagram.

Once bricks are in, fit the retainer over the top to hold them in place.

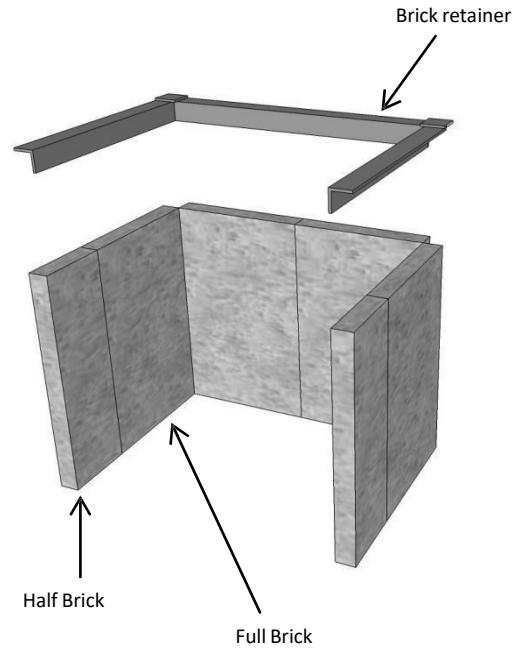

9. FIT AIR SLIDE HANDLE

The Air Slide handle used for controlling the amount of air supplied to the fire needs to be fitted.

Open the door of the appliance, and position the handle with the two holes in the handle located over the threaded holes in the air slide. Place a washer over each of the M6 x 6mm screws, insert the screw through the handle and screw into the air slide. Tighten with the 4mm allen key supplied.

If N60 Naked model, fasten the handle to the air slide using the left and centres holes.

If N60 Curved or Tiled Side models, fasten the handle to the air slide using the right and centre holes.

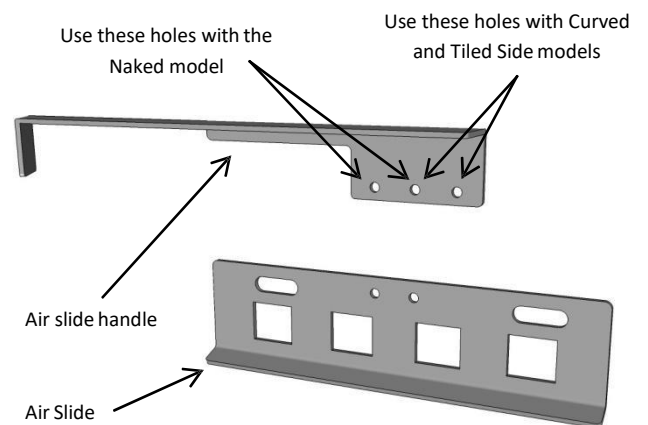

10. FITTING TILED OR CURVED SIDES

- 1) Position the curved or tiled side panel parallel to the corresponding left or right side of the heater.
- 2) Hook the front edge of the side panel over the front edge of the heater.
- 3) While maintaining pressure against the front edge of the panel, bring the rear edge of the panel around so that it overlaps the rear edge of the heater.
- 4) Push the rear edge of the side panel in enough that the three pre-drilled screw holes go past the 6mm thick side panel of the heater.
- 5) Screw three screws (supplied with side panels) in to the pre-drilled holes along the rear edge of the side panel so that the side panel cannot come away from the heater.

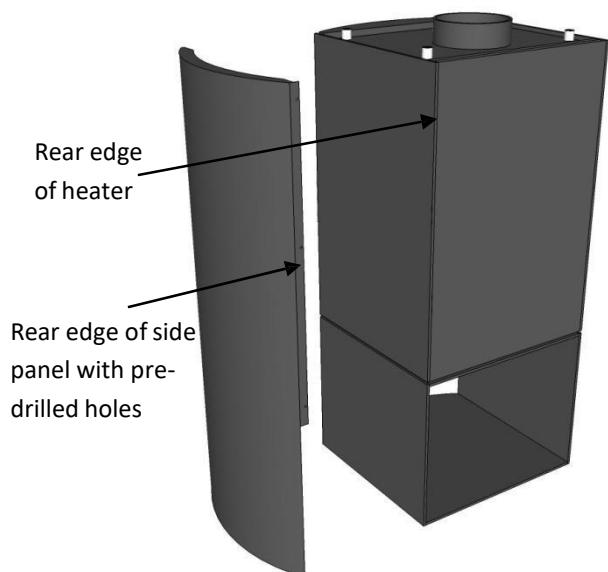
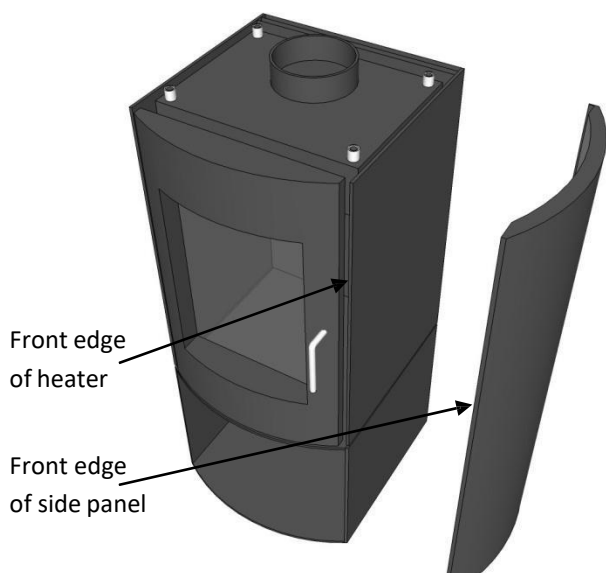

11. TECHNICAL DRAWINGS

Naked Model:

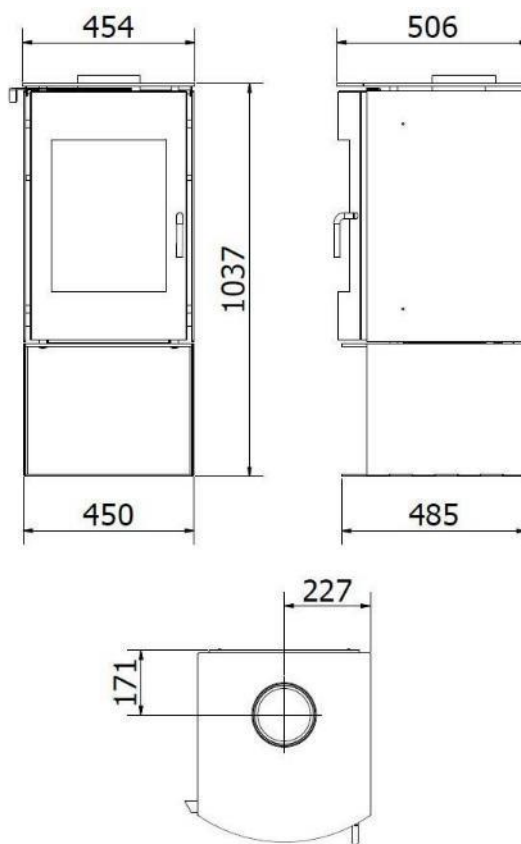

Curved Model:

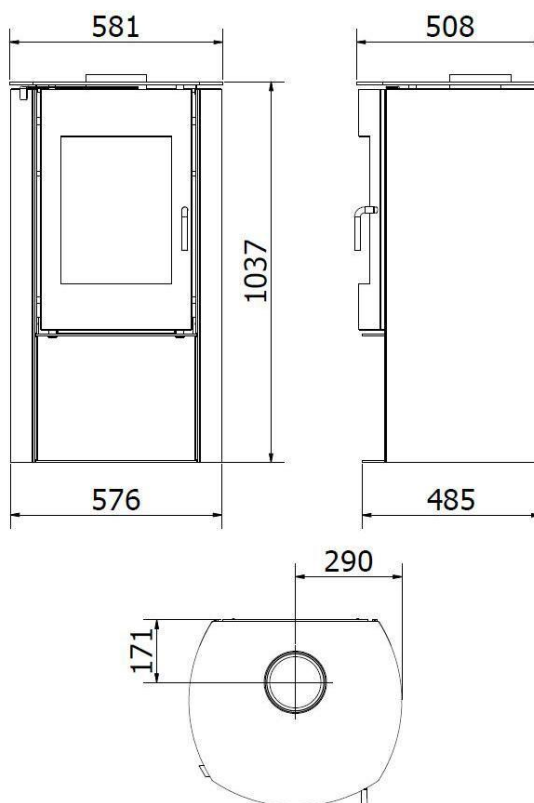

Tiled Side Model:

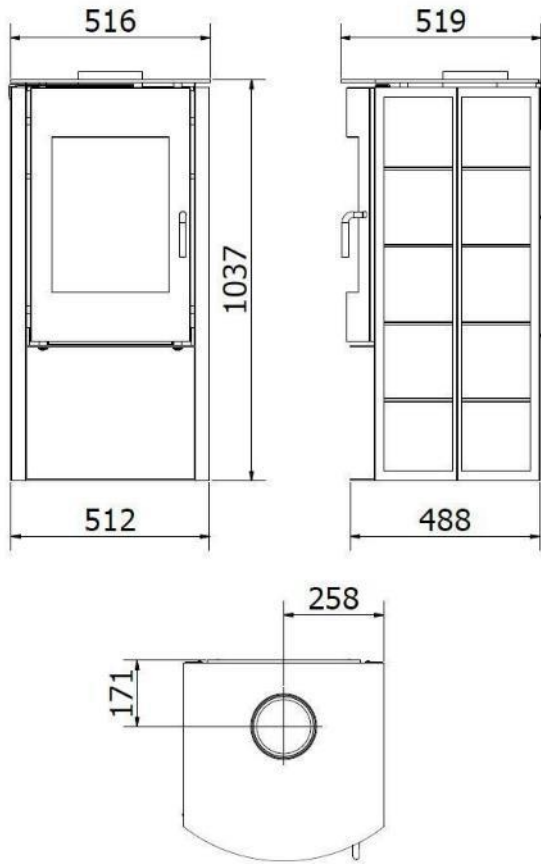

Glen Dimplex
AUSTRALIA

Glen Dimplex Australia Pty Ltd

1340 Ferntree Gully Road,
Scoresby Victoria 3179
Australia

T: 1300 556 816 | F: 1800 058 900
Email: sales@glendimplex.com.au