

# ERGOFOCUS: INSTALLATION AND USER MANUAL

---

1. TECHNICAL DATA	2
2. PRE-INSTALLATION	3
3. INSTALLATION	5
4. OPERATION	11
5. TESTING	13

---

Keep for future use



focus

oblica

**OBLICA**

200 Argyle St  
Fitzroy VIC 3065  
03 9416 0400

# 1. TECHNICAL DATA

## WEIGHT AND DIMENSIONS:

Firebox diameter	950mm
Firebox weight	63Kg
Flue diameter	219mm
Flue weight	16Kg/meter
Standard bracket weight	20Kg
External flue kit	Triple skin 200/250/300mm

## DETERMINED UNDER TEST CONDITIONS:

Nominal thermal output	5kW
Efficiency	46,1%

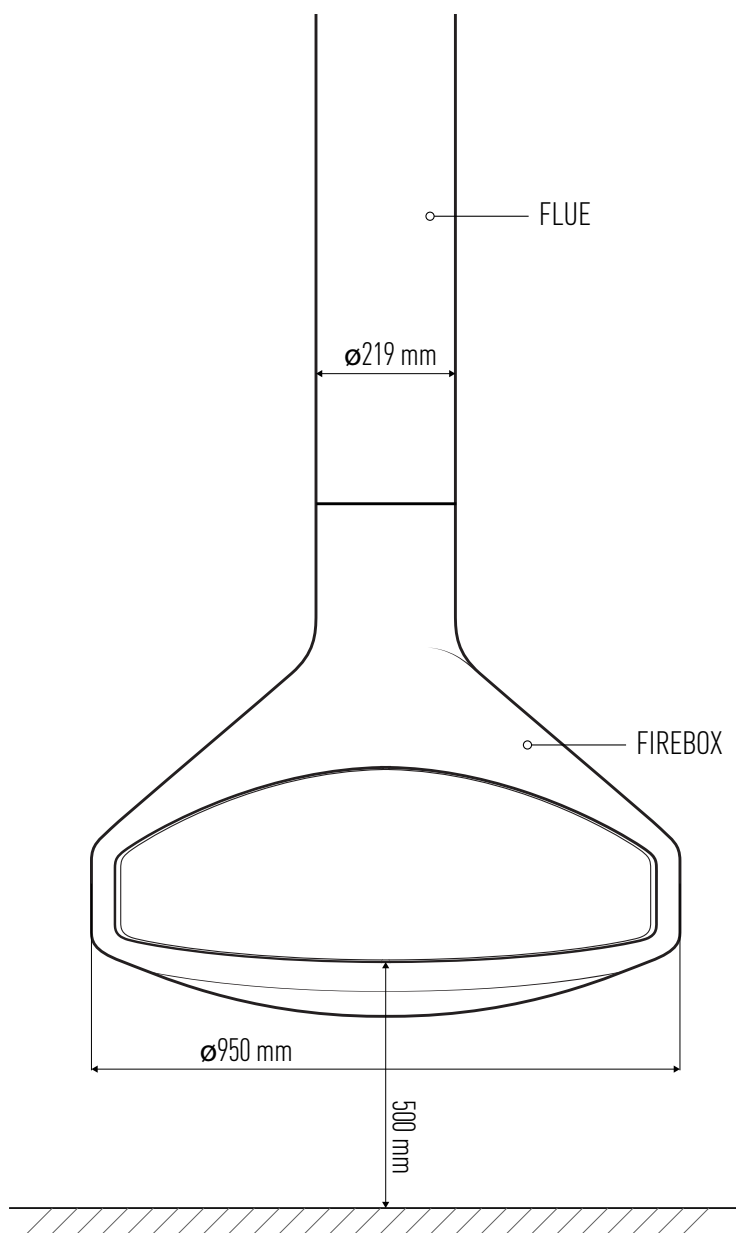

## 2. PRE-INSTALLATION

Congratulations on your purchase of the ErgoFocus. This appliance should be installed and checked by a qualified professional. Ensure you have read the operation guidelines thoroughly prior to first use. For any questions or concerns please contact Oblica on 03 9416 0400.

The installation process is outlined below:

- Determine position of firebox and flue carefully observing the clearances described within this section
- Install the suspension bracket
- Install the external flue
- Install the internal flue and engage the firebox
- Ensure the floor has adequate protection

### **CAUTION:**

Using components or parts other than those provided by the manufacturer or modifying the specification of components may result in inferior or unsafe operation. If such action is necessary, consult the manufacturer in the first instance.

### **WARNING:**

- The appliance and flue-system must be installed in accordance with AS/NZS 2918 and the relevant building code or codes.
- Any modification of the appliance that has not been approved in writing by the testing authority will be in breach of the approval granted for compliance with AS/NZS 4013.
- Once the flue has been installed and approved by a professional installer, the flue must not be modified in any way.

# 2. PRE-INSTALLATION (CONTINUED)

## MINIMUM CLEARANCE — INTERNAL

### 2.1 Clearance from non-combustible surfaces (eg masonry)

100mm minimum clearance is required from fully non-combustible surfaces.

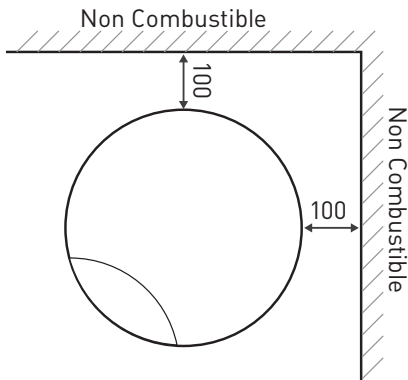

### 2.2 Clearance from glass

500mm minimum clearance is required from normal non-combustible glass.

350mm minimum clearance is required from toughened glass.

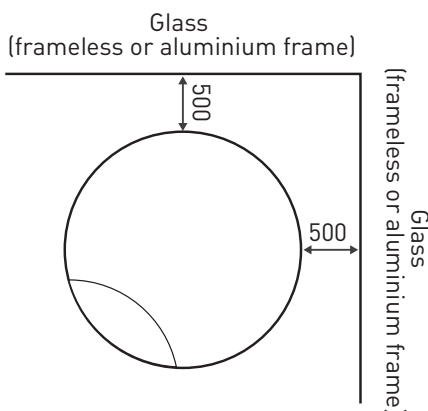

#### IMPORTANT:

Frames must also be considered. Timber window frames must be treated as combustible surfaces (see 2.3). Aluminium frames can be treated as non-combustible surfaces (see 2.2).

### 2.3 Clearance from combustible surfaces (eg timber joist & plasterboard)

1200mm minimum clearance is required on all sides when the ErgoFocus can rotate 360°.

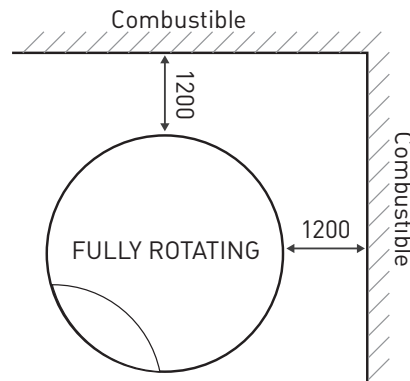

700mm minimum clearance is required if the rotation of the ErgoFocus is locked at 120° or 90° away from the wall. Locking the ErgoFocus so that the opening is fixed is an option available on purchase.

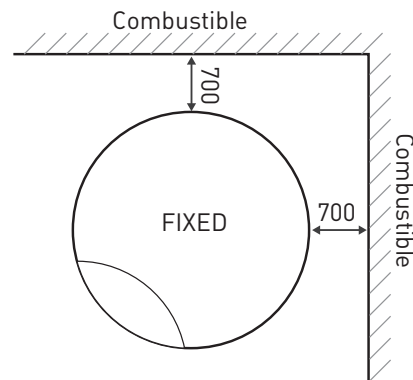

Clearances may be reduced with the application of heat shielding to walls in accordance to the Australian Building Code.

For information on heat shielding please contact our office on 03 9416 0400 or email [info@oblica.com.au](mailto:info@oblica.com.au).

# 3. INSTALLATION

## 3.1 Installing the suspension bracket

- The bracket must be structurally secured within the roof as shown in the diagram below.
- The largest cylinder must project down from the ceiling by at least 150mm (BCA requirement) unless the ceiling is made from a non-combustible material such as concrete.
- You must leave a 25mm clearance gap between the bracket and the ceiling. This gap will be covered by the ceiling Flange.
- 12mm ventilation gap between the plasterboard and the ceiling flange
- 25mm minimum clearance from the triple skin flue to any combustible material within the roof space
- 40mm minimum overlap of the stainless steel 8" flue into the connector

### TYPICAL FLAT ROOF INSTALLATION

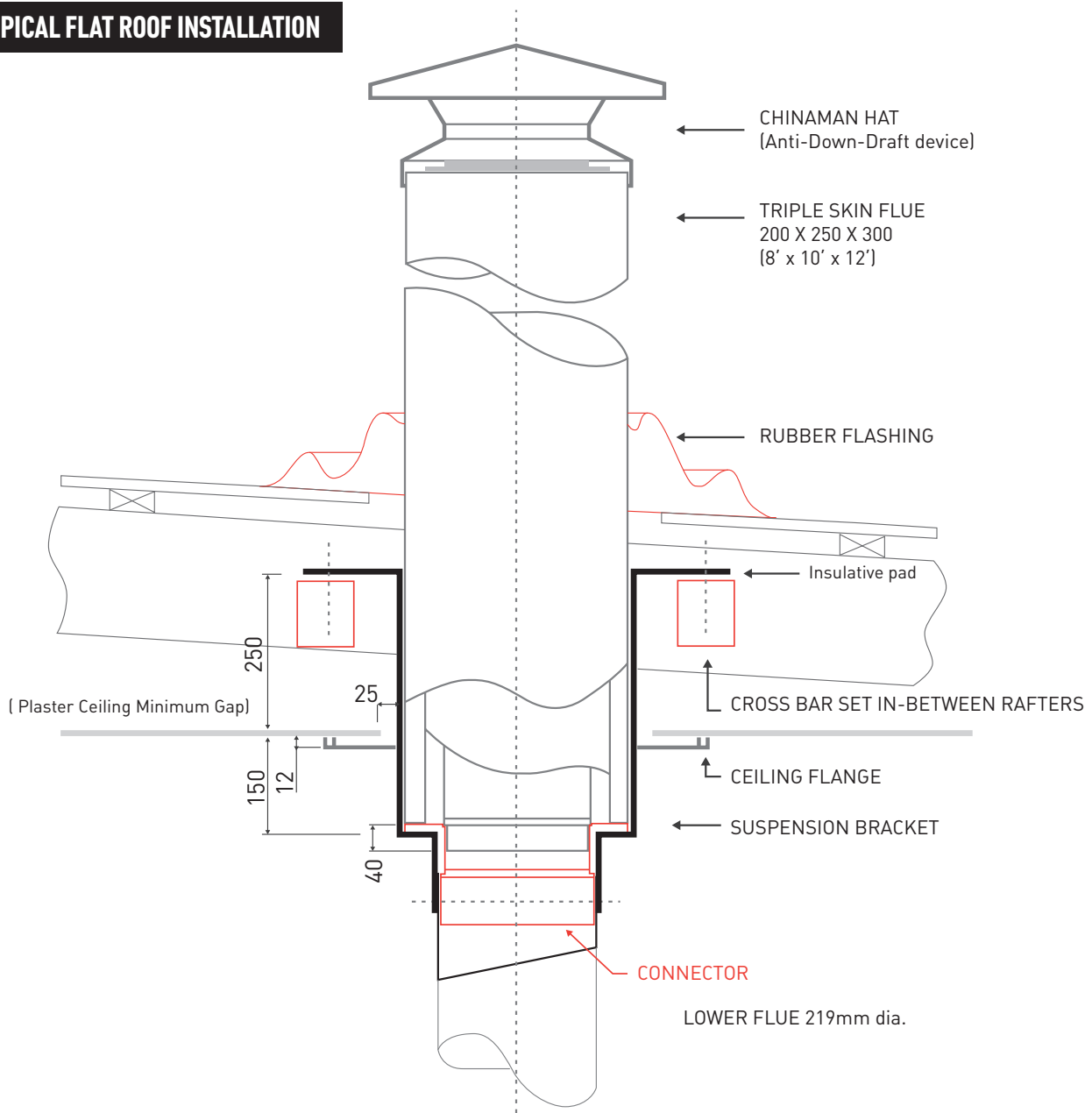

# 3. INSTALLATION (CONTINUED)

## PITCHED ROOF INSTALLATION (CUSTOM MADE BRACKET)

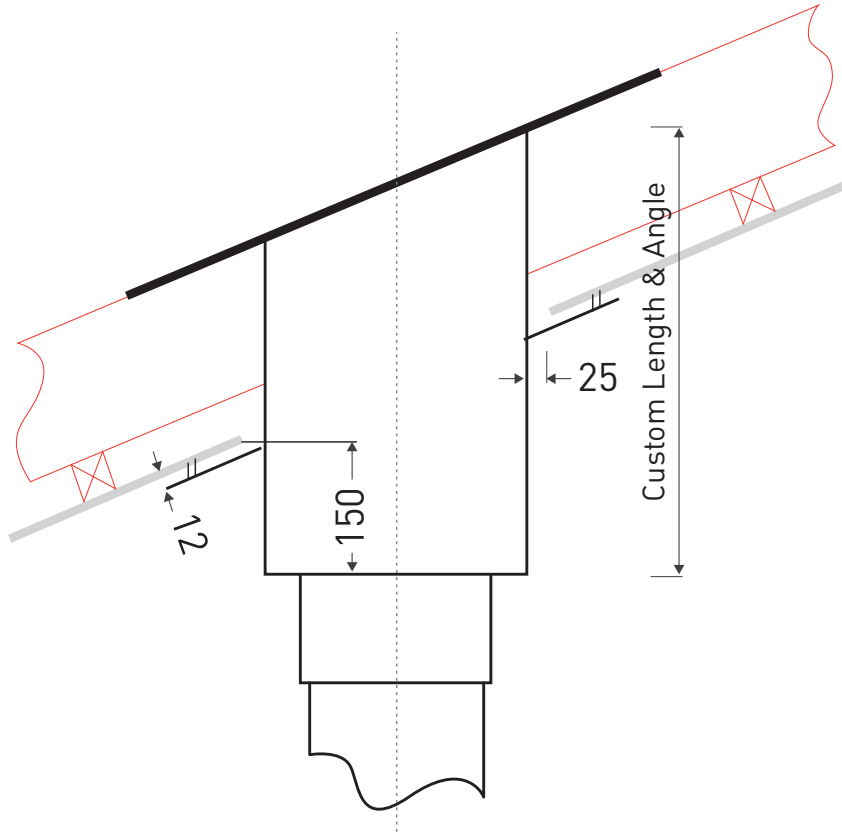

# 3. INSTALLATION (CONTINUED)

## 3.2 Installing the external flue

1. Place the connection piece inside the suspension bracket. This will join the single skin flue below the bracket and the triple skin flue above the bracket which have different diameters.
2. Ensure the triple skin flue is installed as per Australian standards (see diagrams below).

### PITCHED ROOF INSTALLATION

The top of the flue must be 400mm higher than the highest point of the roof. Alternatively, there must be a minimum distance of 3 meters from any higher section of roof.

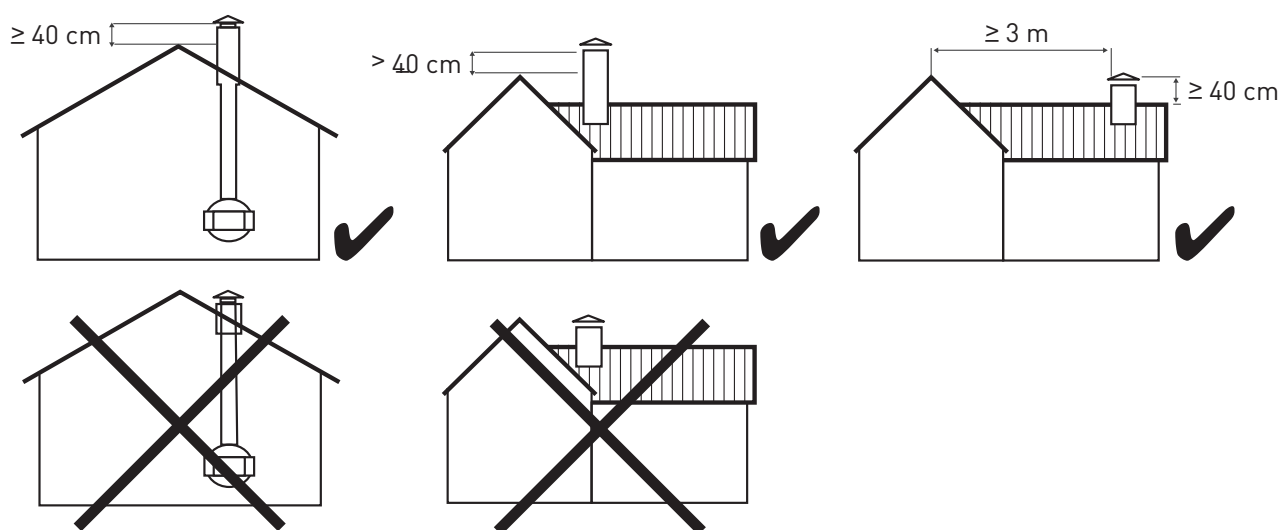

### FLAT ROOF INSTALLATION (LESS THAN 5° PITCH)

The top of the flue must be 1200mm above the roofline. Alternatively, there must be a minimum distance of 3 meters from any higher section of roof.

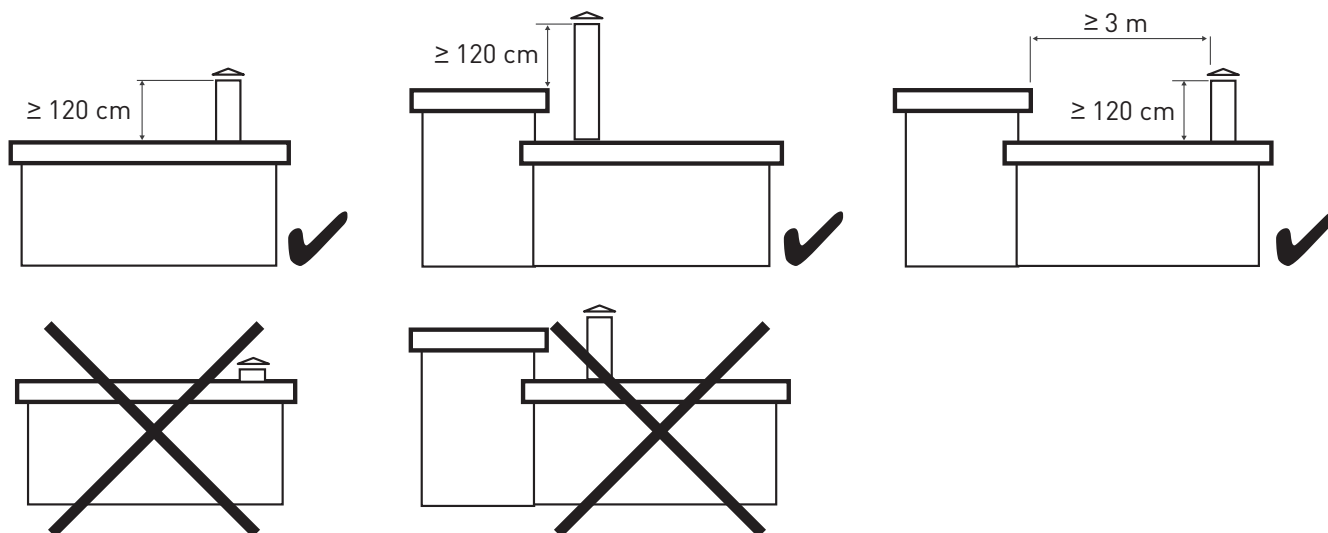

# 3. INSTALLATION (CONTINUED)

## 3.3 Installing the internal flue

1. Position the single skin flue inside the suspension bracket and tighten the grab screws. Ensure that the flue is perfectly vertical and the grab screws are tight.

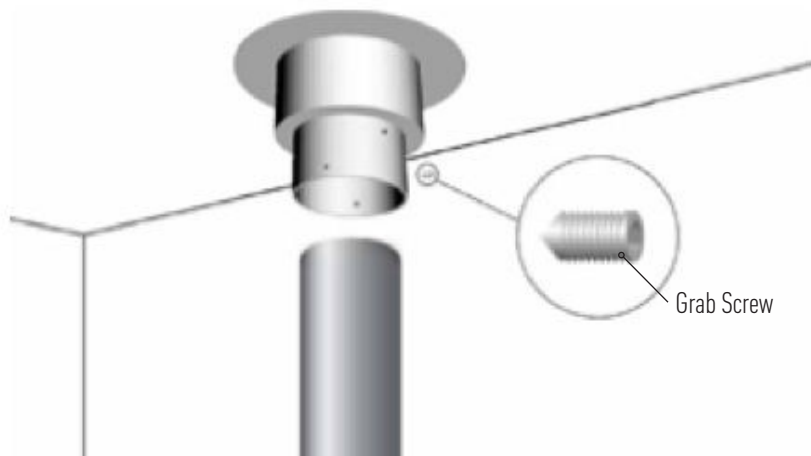

2. Engage the firebox with the bolt bearings as per the diagram below.

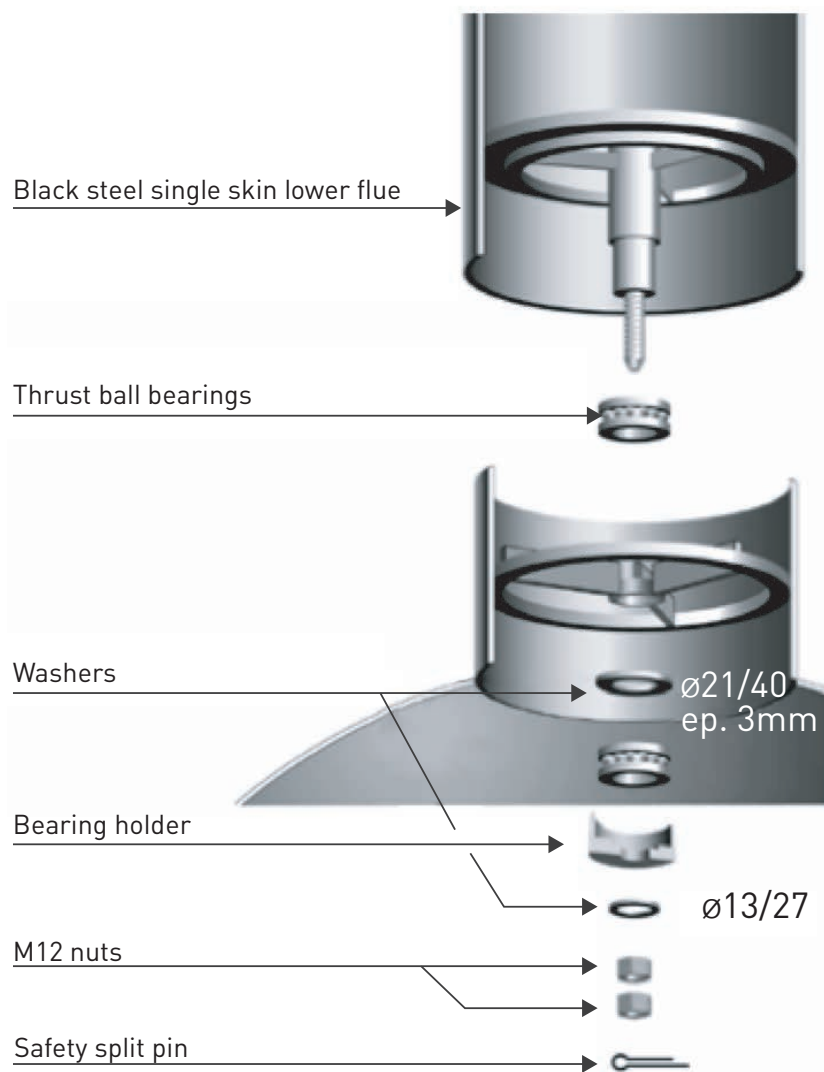



# 3. INSTALLATION (CONTINUED)

## 3.4 Protecting the floor

- Any combustible floor beneath a fireplace must have a floor protector that extends 300mm beyond the diameter of the firebox in all directions.
- If installed directly on combustible material, the floor protector must be made of a 20mm thick sheet of material with a thermal conductivity of 0.21W/m.K. Non-combustible finishes can be applied to the floor protector (tiles, steel sheet, light concrete, etc).
- If the combustible floor is installed on concrete, you can replace the combustible material with non-combustible material laid directly onto the concrete.

### FLOOR PROTECTOR LAID ON TIMBER FLOOR

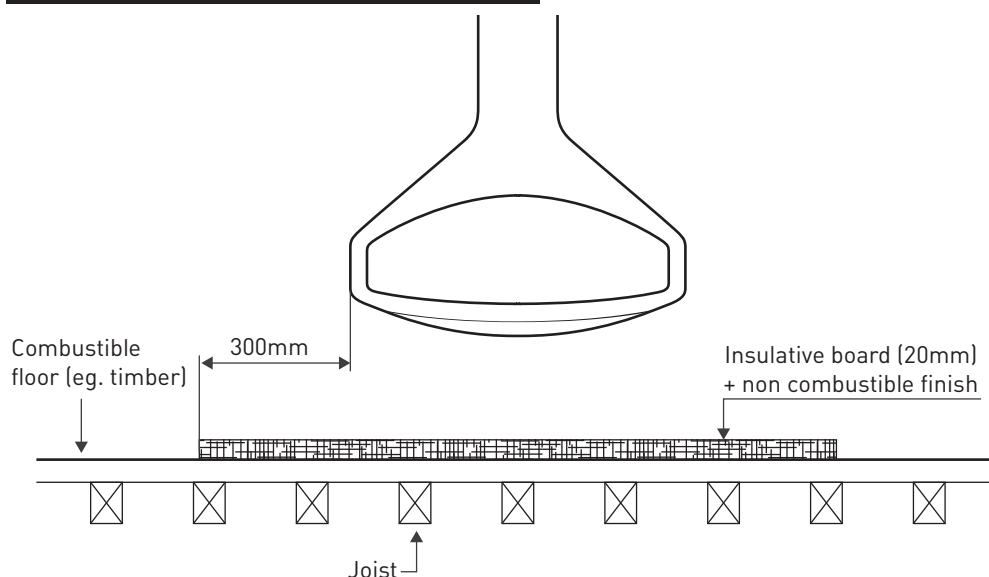

### FLOOR PROTECTOR LAID ON JOIST

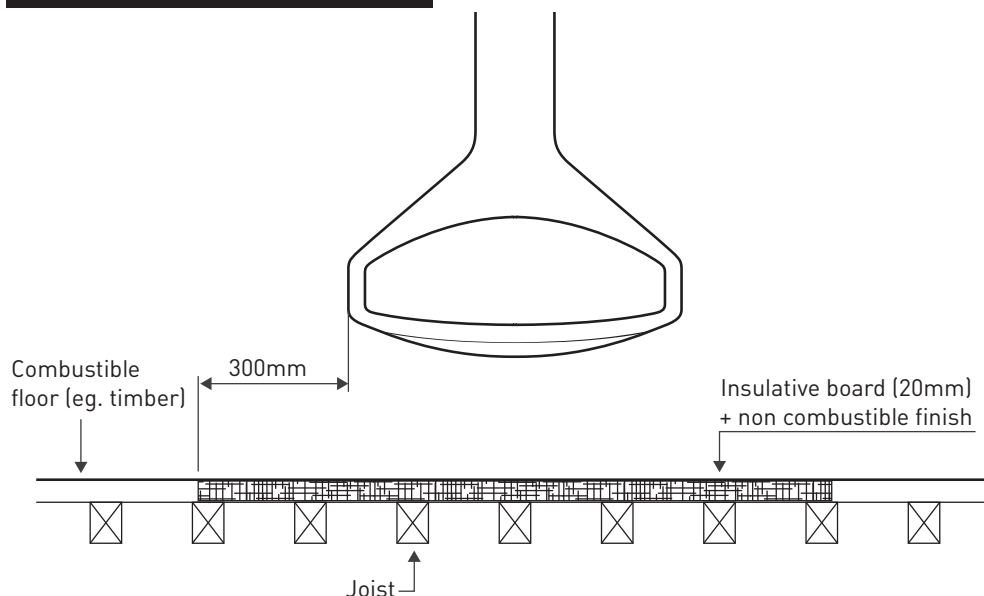

# 3. INSTALLATION (CONTINUED)

## FLOOR PROTECTOR LAID ON CONCRETE

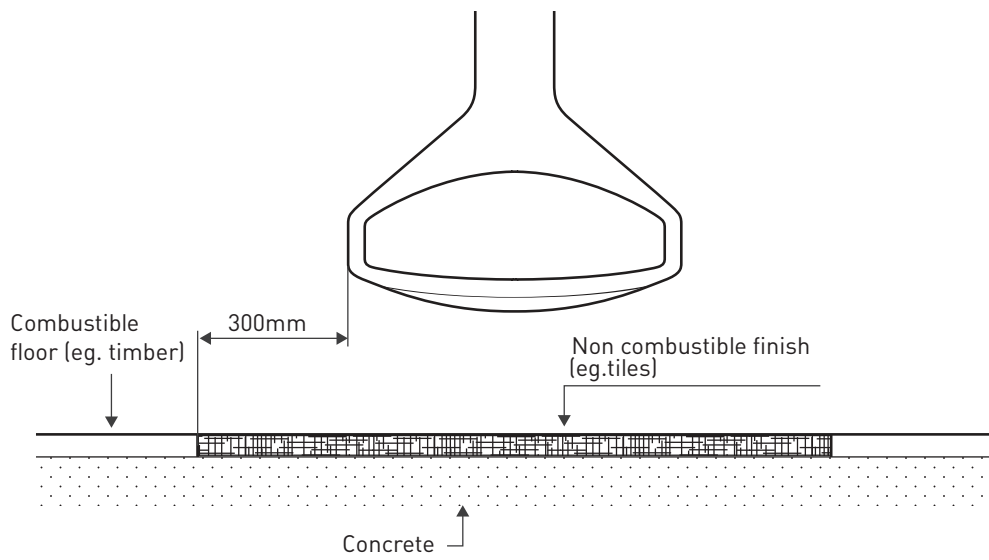

## TOP VIEW

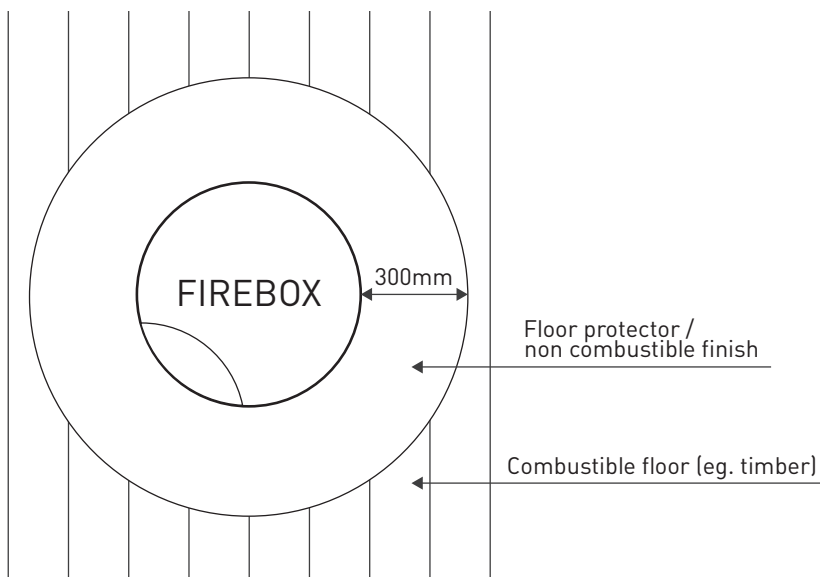

# 4. OPERATION

## 4.1 What you should burn

- Untreated, air dried hardwood
- Split logs with a humidity content of less than 20%

## 4.2 Do not burn

- Trash
- Painted plastic
- Coated or preservative treated wood
- Waste or black coal
- Inflammable liquids
- Fire gels
- Moist wood with a residual humidity content of more than 20% (this may cause sooting of the chimney).

### **IMPORTANT:**

- Misuse may lead to unhealthy and environmentally harmful emissions and will void any warranty or guarantee.
- The maximum load capacity for the ErgoFocus is 20kg of wood.
- Burning only seasoned hardwood helps to protect the environment and lower emissions.

For details of a wood supplier in your area please call our office on 03 9416 0400 or email [info@oblica.com.au](mailto:info@oblica.com.au).

### **WARNING:**

- Do not use flammable liquids or aerosols to start or rekindle the fire.
- Do not use flammable liquids or aerosols in the vicinity of the fireplace when operating.
- Do not store fuel within prescribed installation clearance distances.
- The use of some types of preservative-treated woods as a fuel can be hazardous.

# 5. TESTING

## TEST REPORT N° ATL17-10

**TESTING LABORATORY:**

AHHA Testing Laboratory  
6/26 Stirling st  
Thebarton, SA 5031  
08 8351 8056

**MANUFACTURER:**

Focus – Atelier Dominique Imbert

**MODEL:**

ErgoFocus open style fireplace

**WORK REQUESTED:**

Measure CO2 levels as outlined in AS/NZS 4013:1999 to determine if appliance is excluded from full testing to this standard.

**TEST DATES:**

09/06/2010

**RESULTS:**

The maximum carbon dioxide output by the appliance during the high burn rate prescribed in AS/NZS 4013:1999 was 3.75%.

**CONCLUSION:**

This appliance meets the requirements of AS/NZS 4013:1999 section 1.2.3 (f) and is classified as an excluded appliance.