



nectre







AUSTRALIAN MADE

Established in 1980, the Nectre brand has long been recognised as a honest and reliable wood heater that produces stunning warmth and comfort from a timeless design with easy to operate features. Today, that Nectre warmth and comfort is enjoyed in well over 7 countries.

We are proud of our tradition, history and even more so to be one of the leading Australian wood heater manufacturers. We strive to make the very best heater for value while providing excellent all-round performance. We are driven daily to achieve manufacturing excellence and as such every Nectre wood heater meets or exceeds AS/NZS 4012:2014 and AS/NZS 4013:2014 standards.

The famous Australian Made® logo is the true mark of Aussie authenticity and is Australia's most trusted, recognised and widely used country of origin symbol, underpinned by a third-party accreditation system, which ensures products that carry the logo are certified as 'genuinely Australian'.

Nectre heaters are designed and manufactured right here in Australia, delivering rock-solid build quality, exceptional heating performance and timeless classic design to all Australians.



WOODSTACKER MODEL SHOWN
Size: 460(w) x 450(d) x 905(h)

Nectre N15

If you don't have much space to play with – don't worry. The Nectre 15 is simple, classic and compact but offers an impressive radiant heating capacity of up to 160m². The Nectre 15 is the perfect choice for adding some wood fire magic to any corner of the room. Grab a book and get cosy.

Specifications

Coverage	Up to 160m ²
Heat Output	15kW at peak
Efficiency	86% at peak
Emissions	1.3g/kg
Firebox size	370(w) x 320(d) x 320(h)
Max log width	330
Weight	90kg
Heating style	Radiant

Legs



Size: 460(w) x 450(d) x 665(h)

Pedestal



Size: 460(w) x 450(d) x 730(h)

BurnWise
Sustainable Wood Burning Solutions

*All dimensions are in millimeters (mm) unless specified otherwise and are shown without side shields fitted (if available). In the interest of product development, Glen Dimplex Australia Pty Ltd reserve the right to change N15 product specifications without prior notice.



CURVE SIDE MODEL SHOWN
 Size: 581(w) x 485(d) x 1037(h)

Nectre N60

The Nectre N60 is easily a crowd favourite with its tall, sleek, award winning design. With the choice of white tiled sides, curved sides or naked black sides, it will complement any home's interior design.

Specifications

Coverage	Up to 170m ²
Heat Output	13kW at peak
Efficiency	84% at peak
Emissions	0.60g/kg
Firebox size	345(w) x 275(d) x 450(h)
Max log width	300mm
Weight	190kg
Heating style	Radiant/ Convection

Tiled



Size: 516(w) x 485(d) x 1037(h)

Naked



Size: 454(w) x 485(d) x 1037(h)



*All dimensions are in millimeters (mm) unless specified otherwise and are shown without side shields fitted (if available). In the interest of product development, Glen Dimplex Australia Pty Ltd reserve the right to change N60 product specifications without prior notice.



Nectre MK1

The Nectre Mk1 is one of the best performing radiant heaters for output, coverage and efficiency. The Mk1 is right at home in any living space while providing charm, warmth and comfort. Easy to operate features makes it one of our favourite heaters.

Specifications

Coverage	Up to 200m ²
Heat Output	22kW at peak
Efficiency	81% at peak
Emissions	0.95g/kg
Firebox size	580(w) x 315(d) x 340(h)
Max log width	500mm
Weight	115kg/ 120kg
Heating style	Radiant

Legs



Size: 725(w) x 420(d) x 690(h)

Pedestal



Size: 725(w) x 420(d) x 725(h)



*All dimensions are in millimeters (mm) unless specified otherwise and are shown without side shields fitted (if available). In the interest of product development, Glen Dimplex Australia Pty Ltd reserve the right to change MK1 product specifications without prior notice.



Nectre MK2

The Nectre Mk2 is a simple but elegant radiant/convection heater that circulates warmth effectively throughout any living space. Mk2 pushes out an impressive peak 20kW.

Specifications

Coverage	Up to 200m ²
Heat Output	20kW at peak
Efficiency	81% at peak
Emissions	0.80g/kg
Firebox size	515(w) x 305(d) x 330(h)
Max log width	450
Weight	140kg/ 160kg
Heating style	Radiant/ Convection

*Optional 3 speed fan for pedestal only

Legs



Size: 750(w) x 445(d) x 745(h)

Pedestal



Size: 750(w) x 445(d) x 680(h)



*All dimensions are in millimeters (mm) unless specified otherwise and are shown without side shields fitted (if available). In the interest of product development, Glen Dimplex Australia Pty Ltd reserve the right to change MK2 product specifications without prior notice.



Nectre MK3

The Nectre Mk3 is built with an approved wood stack base together with deeper firebox which makes it not only look good but performs brilliantly as a radiant/convection hardwood heater. Standard remote control 3 speed fan is a welcome addition.

Specifications

Coverage	Up to 270m ²
Heat Output	21kW at peak
Efficiency	66% at peak
Emissions	1.1g/kg
Firebox size	530(w) x 400(d) x 330(h)
Max log width	450
Weight	160kg
Heating style	Radiant/ Convection

*3 speed remote control fan comes as standard

Woodstacker



Size: 750(w) x 541(d) x 820(h)

BurnWise

*All dimensions are in millimeters (mm) unless specified otherwise and are shown without side shields fitted (if available). In the interest of product development, Glen Dimplex Australia Pty Ltd reserve the right to change Mk3 product specifications without prior notice.



Nectre MEGA

The MEGA is designed to cover larger living spaces and provide superb warmth from its radiant convection design. It fits well in both traditional and contemporary styles and can even come with an optional factory fitted central heating boiler for sustainable living.

Specifications

Coverage	Up to 340m ²
Heat Output	25kW at peak
Efficiency	65% at peak
Emissions	1.5g
Firebox size	600(w) x 430(d) x 320(h)
Max log width	500
Weight	170kg/ 180kg
Heating style	Radiant/ Convection

*Optional 3 speed fan & central heating boiler

Legs



Size: 760(w) x 540(d) x 826(h)

Pedestal



Size: 760(w) x 540(d) x 826(h)

BurnWise

*All dimensions are in millimeters (mm) unless specified otherwise and are shown without side shields fitted (if available). In the interest of product development, Glen Dimplex Australia Pty Ltd reserve the right to change Mega product specifications without prior notice.



Nectre Inbuilt

The Nectre Inbuilt delivers natural convection warmth with all the charm and comfort you expect from a Nectre. Nectre Inbuilt is an all-round performer with the style and easy to use functions and it will fit into most existing fireplaces.

Specifications

Coverage	Up to 160m ²
Heat Output	13kW at peak
Efficiency	70% at peak
Emissions	0.90g/kg
Firebox size	500(w) x 325(d) x 370(h)
Max log width	430mm
Weight	120kg
Heating style	Radiant/ Convection

*3 speed remote control fan comes as standard

Inbuilt



Size: 725(w) x 541(d) x 578(h)



*All dimensions are in millimeters (mm) unless specified otherwise and are shown without side shields fitted (if available). In the interest of product development, Glen Dimplex Australia Pty Ltd reserve the right to change Inbuilt product specifications without prior notice.



Nectre N900

The Nectre N900 is one of the largest open burning wood heaters on the market. With its versatility in installation; freestanding, freestanding woodstacker, built-in or masonry insert, the N900 can become the centrepiece of any room or undercover alfresco area.

Specifications

Coverage	Up to 100m ²
Heat Output	15kW at peak
Firebox size	880(w) x 340(d) x 320(h)
Max log width	600
Weight	Up to 250kg
Heating style	Convection
*3 speed remote control fan comes as standard	

Freestanding



Size: 1037(w) x 625(d) x 1128(h)

Inbuilt



Size: 1037(w) x 625(d) x 667(h)

*All dimensions are in millimeters (mm) unless specified otherwise and are shown without side shields fitted (if available). In the interest of product development, Glen Dimplex Australia Pty Ltd reserve the right to change N900 product specifications without prior notice.



Nectre Bakers Oven

The Nectre Bakers Oven provides excellent warmth and cooking performance. With a small footprint it fits in just about any living space without being obtrusive. The cook top adds a warming or direct cooking option with removable rings.

Specifications

Coverage	Up to 120m ²
Heat Output	15kW at peak
Firebox size	340(w) x 300(d) x 380(h)
Max log width	300
Weight	120kg
Heating style	Radiant
*Optional factory fitted domestic hot water booster	

Freestanding



Size: 550(w) x 535(d) x 825(h)

*All dimensions are in millimeters (mm) unless specified otherwise and are shown without side shields fitted (if available). In the interest of product development, Glen Dimplex Australia Pty Ltd reserve the right to change Bakers Oven product specifications without prior notice.



Nectre Big Bakers Oven

The Nectre Big Bakers Oven produces amazing radiant warmth and coverage. Designed with character and charm the Big Bakers Oven provides a spacious oven for those Sunday roasts. The cook top adds a warming or direct cooking option with removable rings.

Specifications

Coverage	Up to 200m ²
Heat Output	18kW at peak
Firebox size	485(w) x 295(d) x 300(h)
Max log width	445
Weight	220kg
Heating style	Radiant
*Optional factory fitted domestic hot water booster	

Freestanding



Size: 690(w) x 535(d) x 828(h)

*All dimensions are in millimeters (mm) unless specified otherwise and are shown without side shields fitted (if available). In the interest of product development, Glen Dimplex Australia Pty Ltd reserve the right to change Big Bakers Oven product specifications without prior notice.

Nectre Product Reference Guide

		N15			N60			Mk1		Mk2		Mk3	
		Radiant			Radiant / Convection			Radiant		Radiant / Convection		Radiant / Convection	
		Traditional			Contemporary			Traditional		Traditional		Traditional	
		Legs	Woodstacker	Pedestal	Naked	Curved	Tiled	Legs	Pedestal	Legs	Pedestal	Woodstacker	
		Black			Black			Black		Black		Black	
Tested with Fan		No			No			No		No	Yes	Yes	
Performance	Output (Kilowatts)	Peak	15			13			22		20		21
		Ave.	13			11			19		18		18
	Emissions	1.3			0.60			0.95		0.80 1.3		1.1	
		Efficiency (%)	Peak	86			84			81		67 79	
Ave.	79			73			73		61 73		62		
Coverage	squares	13-17			14-18			18-22		18-22		24-28	
	m ²	120-160			130-170			170-200		170-200		240-270	
Specification	Heater Size	kg	90	127	90	190	190	190	115	120	140	160	160
		(w)	460	460	460	454	581	516	725	725	750	750	750
		(d)	450	450	450	485	485	485	420	420	445	445	541
		(h)	665	905	730	1037	1037	1037	690	725	680	745	820
	Log Size (max)	mm	330			300			500		450		450
	Firebox size	m ³	0.038			0.043			0.062		0.052		0.070
	Fabricated	Steel	6			6			6		6		6 & 8
Clearance	Hearth (min)	(w)	900	900	900	720			900		900		900
		(d)	900	900	900	740			900		900		900
		Thickness	15	15	15	7.5			15		15		15
	900mm Rear Flue Shield	Rear	175	175	175	75	100	100	140		125		150
		Side	750	750	750	450	190	285	650		450		400
		Corner	750	750	750	225	125	125	500		200		150
		Front	300	300	300	300			400		400	350	300
	900mm Rear Flue Shield + Side Shields	Rear	125	240	125				140				
		Side	450	550	450				500				
		Corner	225	300	225				300				
		Front	300	300	300				400				
	Decro-mesh with 900mm Inner Reflector	Rear	175	175	175	125	150	125	140		125		150
		Side	750	750	750	450	150	240	650		350		400
		Corner	750	750	750	225	125	125	500		125		150
		Front	300	300	300	300			400		400	350	300
	Decro-mesh with 900mm Inner Reflector + Side Shields	Rear	175	240	175				140				
		Side	450	550	450				500				
		Corner	225	300	225				275				
		Front	300	300	300				400				
	200mm Solid Flue Outer with 900mm Inner Reflector	Rear	175	240	175				140		125		150
Side		750	550	750	125	150	125	650		350		400	
Corner		750	300	750	450	150	240	500		100		125	
Front		300	300	300	225	125	125	400		400	350	300	
Options	Fan (manual)	3 Speed									Yes		
	Fan (remote)	3 Speed											Yes
	Shields	Side	Yes						Yes				
	Trivet	Cast	Yes										



For the very best performance out of a Nectre wood heater, we recommend only burning dry seasoned hardwood. Pre-season maintenance check and a possible flue clean will ensure excellent Nectre performance. Avoid using salt borne drift wood, pine and/or chemically treated woods.

It is recommended that a qualified person/s carry out the installations in accordance to all specifications contained within this document, and with all relevant building codes. Glen Dimplex Australia Pty Ltd reserves the right to change or alter drawings, specifications or dimensions without prior notice. The information contained within the document was correct at time of printing.

Nectre Product Reference Guide

		MEGA		Inbuilt		Bakers Oven		
		Radiant / Convection		Radiant / Convection		Radiant		
		Traditional		Traditional		Traditional		
		Legs	Pedestal	n/a		Original	BIG	
		Black		Black		Black		
		Tested with Fan		Yes		No		
Performance	Output (Kilo-watts)	Peak	20	25	13		15	18
		Ave.	16	22	10		11	14
Emissions		1.5		1.5		0.90		n/a
Efficiency (%)	Peak	65		65		70		n/a
	Ave.	62		62		62		n/a
Coverage	squares	30-37		13-17		8-13	17-22	
	m ²	280-340		120-160		75-120	160-200	
Specification	Heater Size	kg	170	180	120		120	220
		(w)	760	760	725		550	690
		(d)	540	540	541		535	535
		(h)	826	826	578		825	825
	Log Size (max)	mm	500		430		300	445
Firebox size	m ³	0.082		0.050		0.039	0.043	
Fabricated	Steel	6 & 8		6		6	6 & 8	
Clearance	Hearth (min)	(w)	900		900		900	900
		(d)	900		400	300	900	900
		Thickness	15		40	110	12	15
	900mm Rear Flue Shield	Rear	200				125	125
		Side	875				350	325
		Corner	450				350	275
		Front	300		400	300	300	300
	900mm Rear Flue Shield + Side Shields	Rear						
		Side						
		Corner						
	Decro-mesh with 900mm Inner Reflector	Rear	200					
		Side	875					
Corner		450						
Decro-mesh with 900mm Inner Reflector + Side Shields	Rear							
	Side							
	Corner							
200mm Solid Flue Outer with 900mm Inner Reflector	Rear	200						
	Side	800						
	Corner	450						
	Front	300						
Options	Fan (manual)	3 Speed	Yes					
	Fan (remote)	3 Speed			Yes			
	Shields	Side						
	Trivet	Cast						

		N900		
		Open fronted		
		Contemporary		
		Firebox only	Wood-stacker	
		Black		
Specification	Heater Size	(w)	1037	1037
		(d)	625	625
		(h)	667	1128
	Log Size (max)	mm	600	
Firebox size	m ³	0.075		
Fabricated	Steel	5		
Clearance	Hearth (min)	(w)	1285	1285
		(d)	1200	1000
		Thickness	5-50**	5-50**
	N900 FS flue kit	Rear	100	100
		Side	500	500
		Corner	25	25
		Front	500***	300***
Fan (remote)	3 Speed	Yes		

		N900		
		Open fronted		
		Contemporary		
		Built-In (ZC)	Masonry Insert	
		Black		
Specification	Heater Size	(w)	1037	1037
		(d)	608	608
		(h)	649	649
	Log Size (max)	mm	600	
Firebox size	m ³	0.075		
Fabricated	Steel	5		
Clearance	Hearth (min)	(w)	1285	1285
		(d)	908-1108*	908-1108*
		Thickness	5-50**	5-50**
	N900 ZC flue kit	Side	550	550
		Front	300-500***	300-500***
Fan (remote)	3 Speed	Yes		

*Dependent on how far the base of the firebox is from the floor
 **Dependent on material used
 ***May be reduced to 300mm if firebox is raised 450 above the floor, equivalent to woodstacker base cabinet

NOTE: Nectre Bakers Oven & Big Bakers Oven emissions and efficiency are shown as n/a, they are classified as a cooking stove and are exempt. All measurements are in millimeters (mm) and are correct at time of print. Glen Dimplex Australia Pty Ltd reserves the right to change or alter product specifications as required.

FLUE REQUIREMENT



The flue system used when installing a Nectre must comply with the current installation standards of AS/NZS2918. Full instructions on the installation of the flue will be supplied with the flue kit and these must be adhered to. The minimum exit height from the top of the floor protector (hearth) must not be less than 4.6m and the minimum exit height above the roof line of the roof ridge as detailed in the instructions.

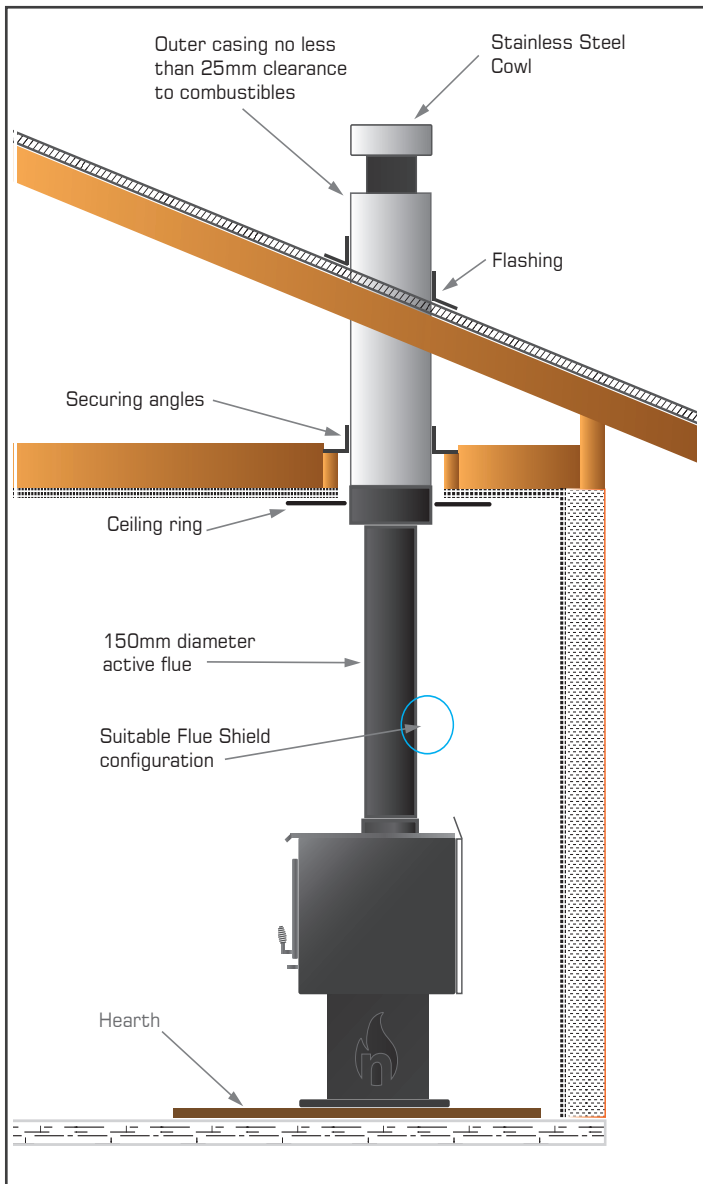

Suitable Flue Shield Configuration



REAR SHIELD

900mm length, minimum 160° arc, stainless steel rear flue shield, can be painted black.

Models suitable for
N15 | Mk1 | Mk2 | Mk3 | Mega
N60 | Bakers Oven's

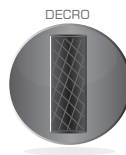

DECROMESH

Decromesh with 900mm inner reflector fitted with DLR

Models suitable for
N15 | Mk1 | Mk2 | Mk3 | Mega
N60

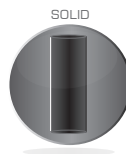

SOLID

200mm Solid flue outer with 900mm inner reflector fitted with DLR

Model suitable for
N15 | Mk1 | Mk2 | Mk3 | Mega
N60



Decromesh Locating Ring (DLR) is supplied with all models where required

New Flue Shielding Options

N60 – The N60 offers the same Rear, Side, and Corner clearances when installed with a “200mm solid flue outer with 900mm inner reflector” as the “Decro-mesh with 900mm inner reflector”.

Mk1 – The Mk1 can be installed with “200mm solid flue outer with 900mm inner reflector” with the same clearances as “Decro-mesh with 900mm inner reflector”, as well as the same results when the side shields are fitted.

Mk2 – The Mk2 can be installed with “200mm solid flue outer with 900mm inner reflector” with Rear = 125mm, Side = 350mm, Corner = 100mm, Front = 400/350mm (same as other shielding options).

Mk3 – The Mk3 can be installed with “200mm solid flue outer with 900mm inner reflector” with Rear = 150mm, Side = 400mm, Corner = 125mm, Front = 300mm.



4.6m Flue from the hearth plus the minimum above the roof line of the roof ridge.

HOW TO CHOOSE A WOOD HEATER?

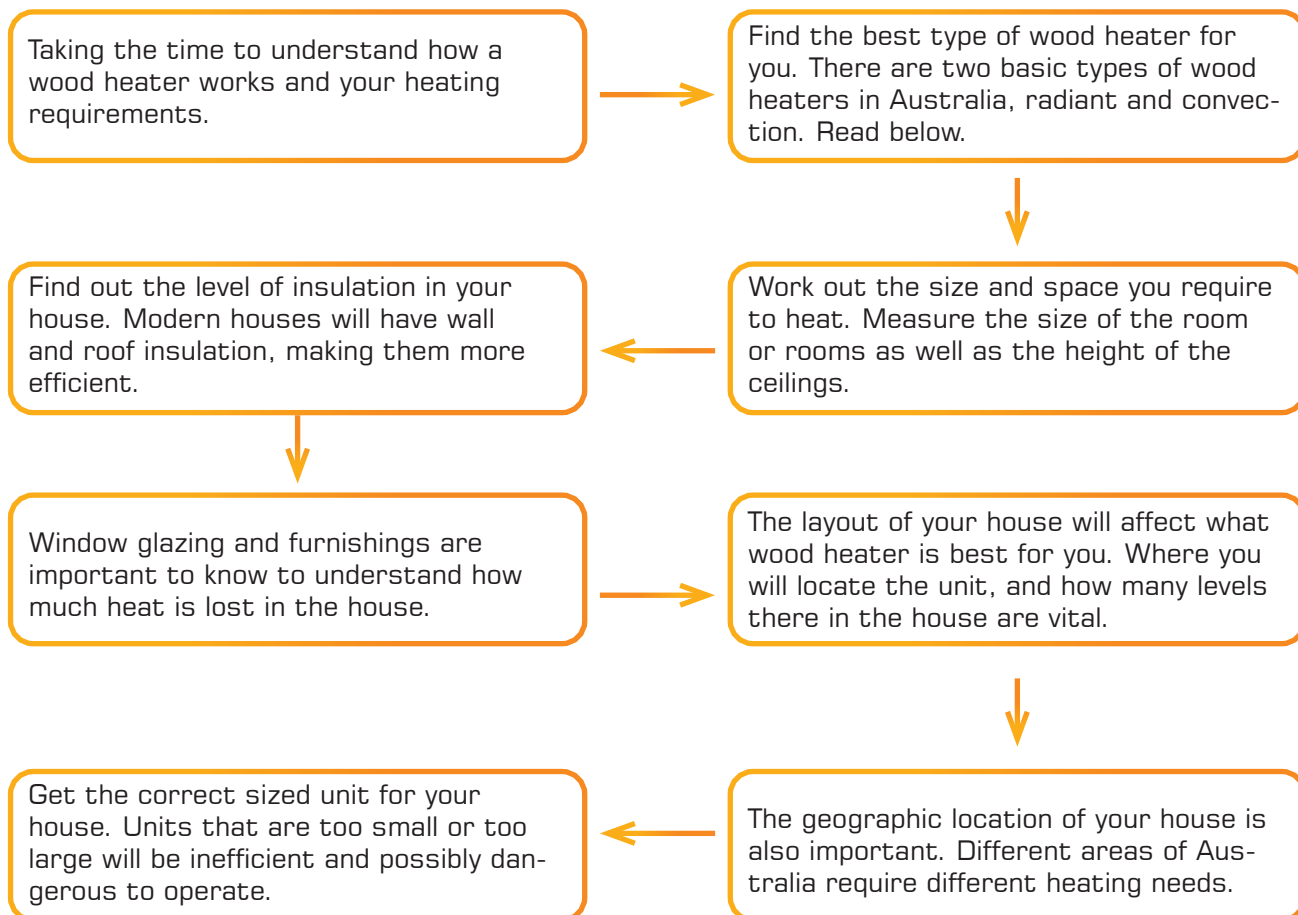

Radiant Heaters (Nectre Mk1 & Nectre N15):-

A radiant heater does not have any outer casings on the firebox except for a rear heatshield. A radiant heater will heat the objects in the room in a straight line from the heater, like an electric bar radiator. Radiant heaters are ideal for rooms with high ceilings and used in conjunction with a ceiling fan is a very effective method of heating. A radiant heater will require a larger clearance to the sides than a convection style heater.

Radiant / Convection Heater (Nectre Mk2, Nectre Mk3, Nectre Mega, Nectre N60, Nectre Inbuilt):-

A radiant/convection heater will emit radiant heat from the front of the heater and the lower top, front step but has a convection chamber built into the sides and rear of the appliance which allows for the addition of a fan to increase the speed of this convection air. The side clearances are also reduced because of these air gaps. A natural convection is created through this chamber depending on the burn rate of the fire but an optional fan can be added to increase the speed of this air movement. No fan available for the N60.

Maintaining a wood fire heater is easier than you may think. Other things to consider are ensuring that the wood you burn is dry, that you regularly clean out the ash when it is cold and keeping the glass door clean.



“We make great wood heaters to
suit contemporary and traditional living”

Glen Dimplex Australia Pty Ltd
8 Lakeview Drive,
Scoresby, VIC 3179
T 1300 554 155
E flame@glendimplex.com.au

Glen Dimplex
AUSTRALIA

Nectre is a registered trademark of
Glen Dimplex Australia Pty Ltd, all rights reserved.

NECBRO21_1

Authorized Nectre Dealer



nectre.com.au