

# Installation Instructions for Jetmaster Universal Wood or Gas



THESE INSTALLATION SHEETS MEET THE MINIMUM REQUIREMENTS OF AS/NZS2918:2018.  
THESE INSTALLATION INSTRUCTIONS ARE BASED ON AMDEL TEST REPORTS M3681/88, M3765/88 AND M5572/89.



## Index

Page 2	General Instructions - Timber frame installation Jetmaster Universal wood or gas
Page 3	Componentry and specifications
Page 4	Frame out for Timber frame installation
Page 5	Timber frame installation
Page 6	Installation glossary timber frame installation
Page 7	Summary of minimum installation specifications
Page 8	Installation diagram full brick chimney
Page 9	Installation full brick chimney
Page 10	Flue heights and terminations
Page 11	Installation into existing fireplace
Page 12	Troubleshooting
Page 13	Fixing trims, fascias and mantelpieces
Page 14	Using your wood fireplace

## Step by step check list

Warning! Please read these instructions carefully. Failure to adequately follow the instructions can result in serious injury or death.

1. Position firebox on a non-combustible hearth - see diagram No 1 Hearth - Summary of minimum installation specs page 7.
2. Bolt gather to firebox.
3. Insulate entire firebox and gather where painted red with the insulation provided.
4. If using a lintel bolt lintel to firebox –insulate between lintel and firebox .You can lay your Hebel or brickwork directly onto the top of the firebox between the gather and front flange of the firebox. However it is important to insulate between the Hebel/brickwork and firebox.Active flue must be sealed to brick or Hebel casing to ensure proper insulation of firebox. Outer flue ventilation above sealed brick of Hebel casing.
5. Ensure air intake area at bottom of unit is not obstructed.
6. Brick or Hebel around firebox to a height 600mm above the firebox. Min 75mm Hebel Power panel can be used.
7. Do not recess the firebox by more than 110mm. A greater dimension could result in convected heat loss.
8. Use the double flue kit provided. Rivet an inner active starter flue with two female ends to gather to allow second length to have crimp facing down.The outer flue is then installed outside active flue with crimp facing up to ensure water penetration on flue above roof runs out.  
Rivet active flues together at crimped joins.  
Fix outer non-active flues to active inner flues use 3 x 25mm self-tapping screws through outer flue at bottom at each join and on top at each join.  
As an alternative, rivet 4 x 25mm conduit saddles at each join top and bottom.  
Ventilate the flues, cut 4 x 25mm notches at bottom of first length of outer flue and top of outer flue in either the ceiling cavity or just below the ceiling. When using a cover cone drill a series of holes into the outer flue below the Cover cone, to ensure adequate ventilation. It's important to ensure airflow between the outer and active flues.  
Flue clearances: A minimum of 50mm clearance must be maintained between outer flue and combustibles.
9. A minimum of 3.6m of flue is to be used.
10. Fit a recommended Jetmaster flue cowl to the top of flue.
11. Gas burning. A ½ inch BSP inlet on right hand side is required. Drill at 100mm from base and rear of firebox from outside of firebox. Avoid penetrating the firebox from the rear.

# Componentry And Specifications

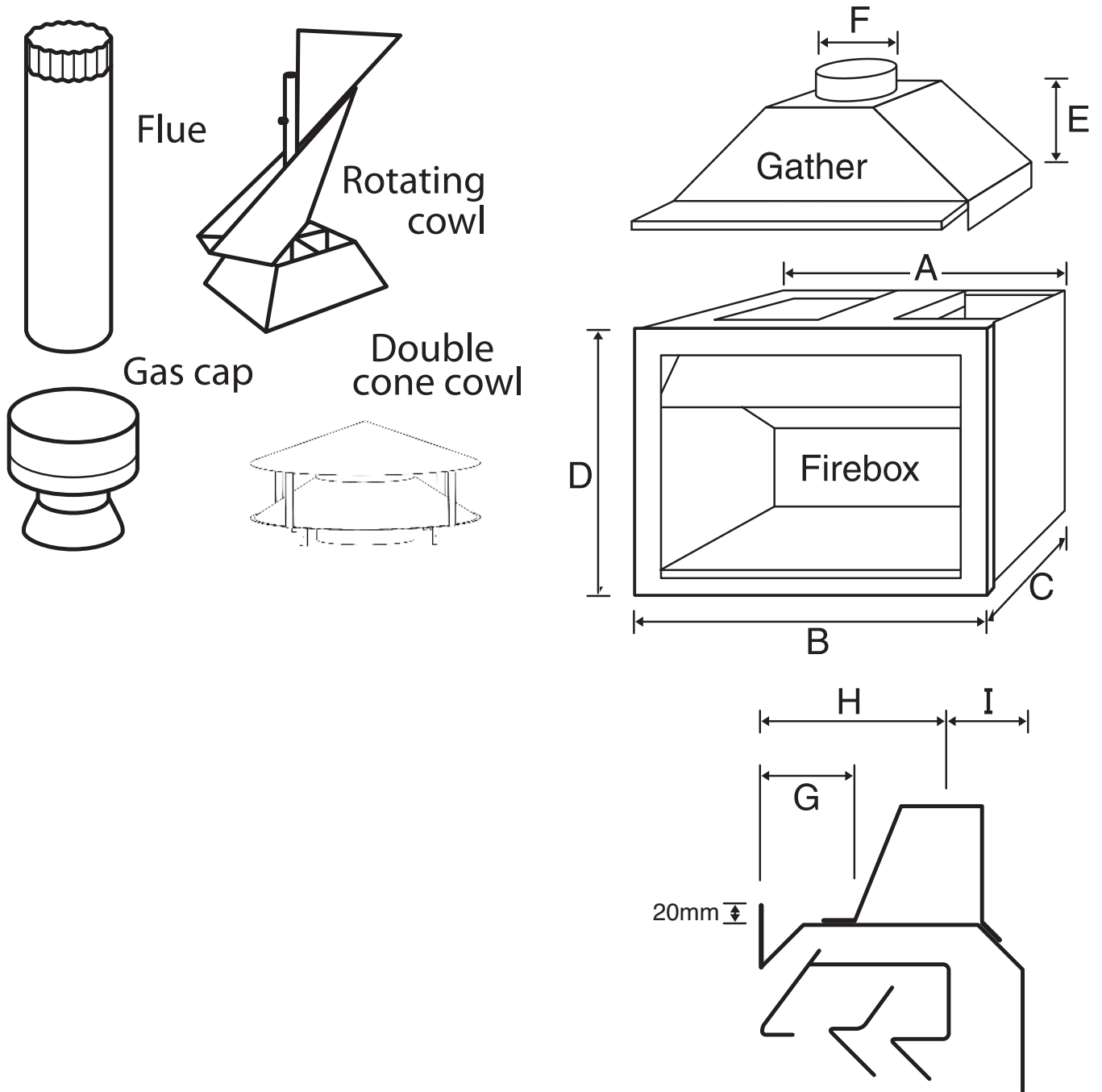

GATHER AND FIREBOX DIAGRAMS (DIMENSIONS IN MILLIMETERS)

MODEL	A	B	C	D	E	F	G	H	I
400	390	440	340	570	200	200	110	195	145
440	470	510	330	610	200	200	80	190	140
500	570	600	350	650	200	200	90	230	120
600	670	700	350	650	200	200	90	230	120
600 Low	670	700	350	600	200	200	90	230	120
700S	770	800	350	650	200	200	90	230	120
700SH Low	770	800	350	600	200	200	90	230	120
700D	770	800	400	700	200	225	100	250	150
850	920	950	450	750	220	250	130	300	150
850 Low	920	950	450	700	220	250	130	300	150
1050 Low/Low	1120	1150	500	700	240	300	150	320	180
1050	1120	1150	500	800	240	300	150	320	180
1200*	1250	1300	600	1000	400	250	300	450	180
1500*	1550	1600	600	1000	400	300	350	450	180

## Frame Out For Timber Frame Installation

NB Frame out allows for 100mm of Hebel on sides and back of firebox with a 25mm clearance from the firebox and 600mm of Hebel above the firebox.

NB It is preferable to install the Unit and flues prior to Timber construction, so mistakes are minimized.

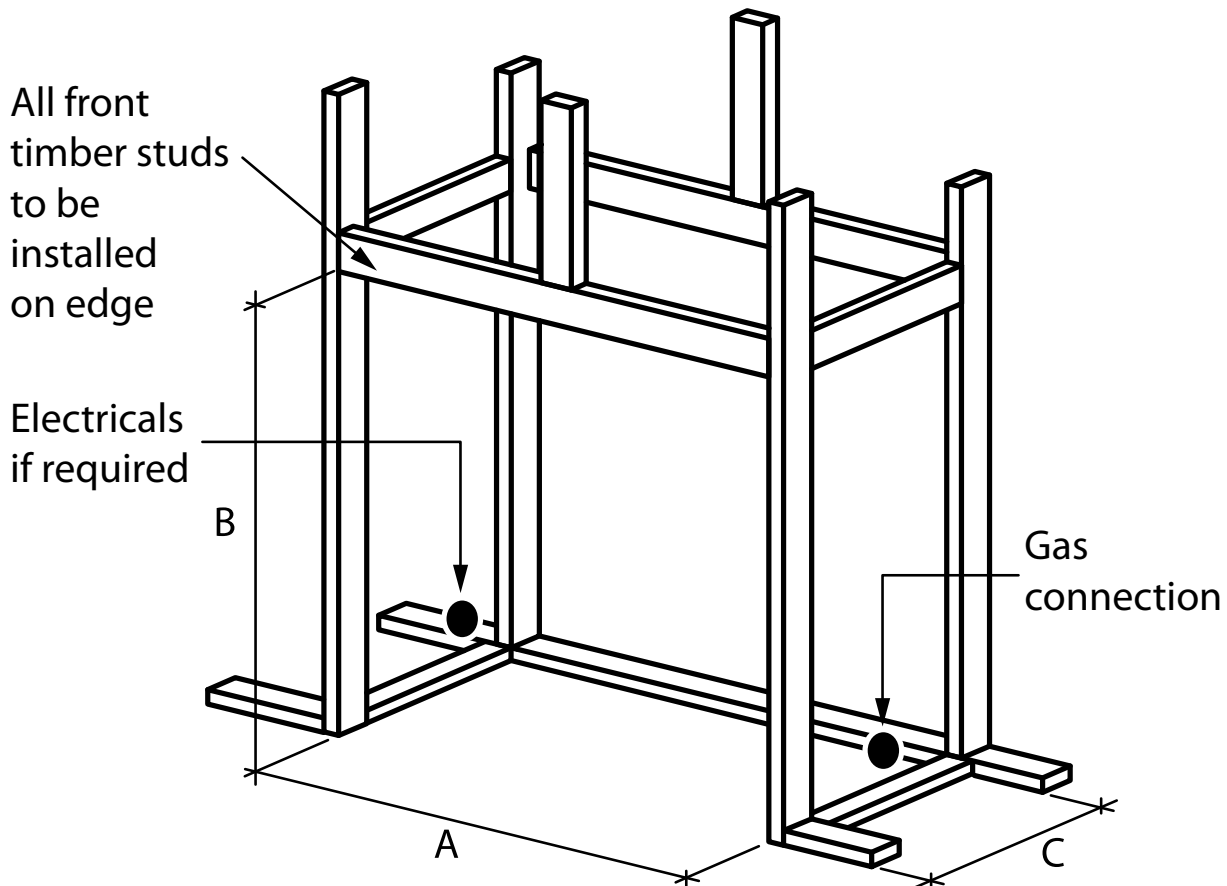

(DIMENSIONS IN MILLIMETERS)

MODEL	A	B	C
400	640	1170	465
440	720	1210	455
500	820	1250	475
600	920	1250	475
600 Low	920	1200	475
700SH	1020	1250	475
700SH Low	1020	1200	475
700D	1020	1300	525
850	1170	1350	575
850 Low	1170	1300	575
1050	1390	1400	625
1050 Low Low	1390	1300	625
1200	1500	1600	725
1500	1800	1600	725

# Diagram for Timber Frame Installation - Wood or Gas

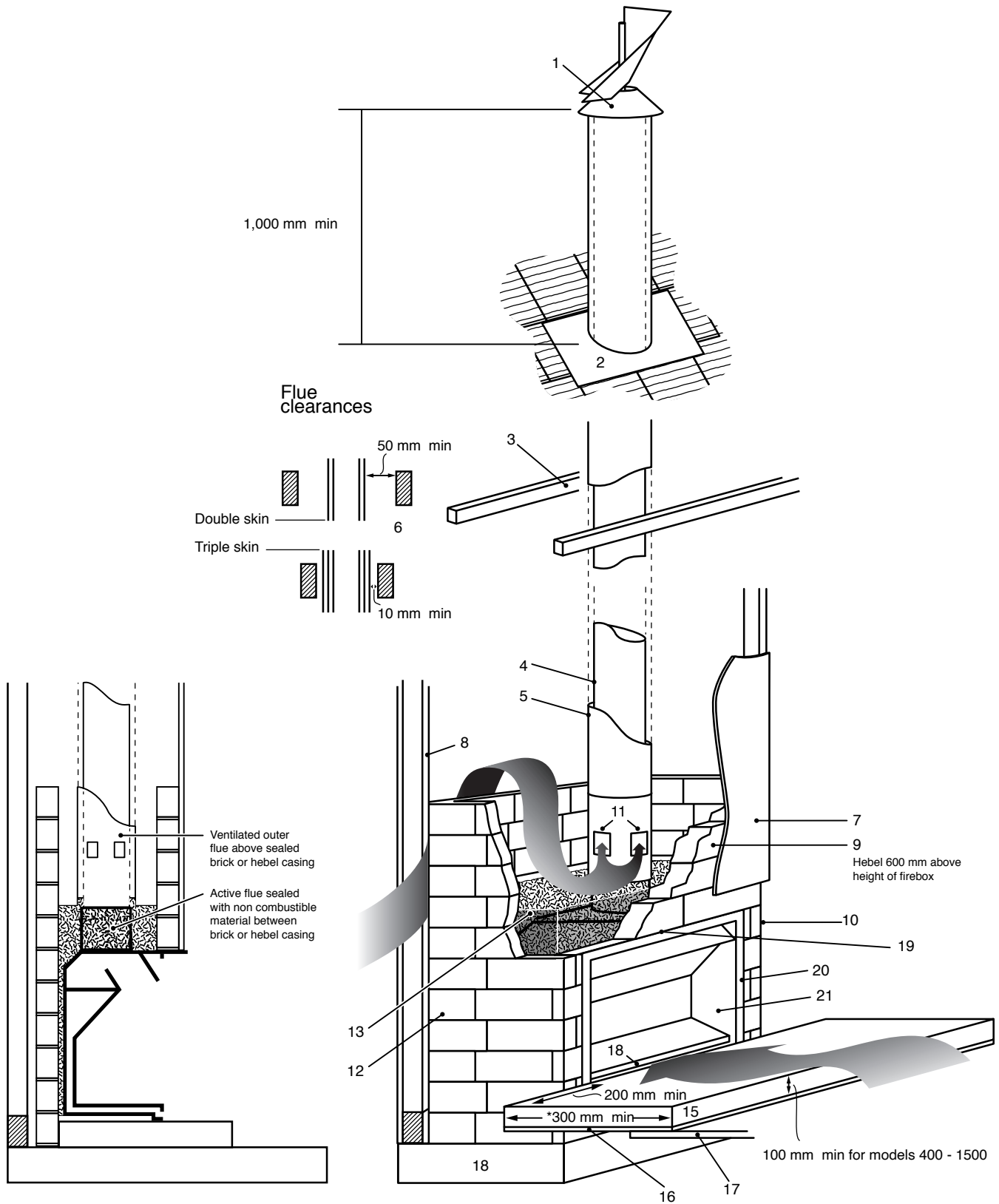

*HEARTH DEPTH	
440-700D =	300mm
850 =	400mm
1050 =	500mm
1200-1500 =	900mm

## Installation Jetmaster Universal Timber Frame Installation - Wood Or Gas

1. Flue Termination. Choose from Rotating cowl. Fixed, Dual Fuel or Chinaman's Hat.  
NB If using Chinaman's Hat allow 120mm clearance from top of flue to hat.  
For gas installation use an approved AGA GAS COWL.
2. Approved flashing.
3. Rafters.
4. Inner Active flue.
5. Outer Flue.
6. If the clearance of the outer flue (5) is less than 50mm to combustibles a second outer flue must be used and its clearance must not be less than 10mm to combustibles. Keep the same clearances for bends.
7. Plasterboard: A 300mm clearance must be kept to the outer flange of the Firebox. If a flush finish or behind the flange finish is required then Villa board or the equivalent should be used.
8. Combustible wall
9. There must be a minimum of 75mm Hebel around the firebox and it must be taken to at least 600mm above the top of the firebox. NB if using bricks then 115mm is required around and 600mm above firebox. Active flue must be sealed to brick or Hebel casing to ensure proper insulation of firebox. Outer flue ventilated above sealed brick or Hebel casing.
10. Timber stud.
11. Make 4 ventilation holes in the outer flue and if a 2nd outer is used repeat. Holes should be 25mm by 50mm each. Do not perforate the active inner flue.
12. A 25mm air gap between Hebel/brickwork and the combustible wall must be kept to allow air to flow behind brickwork/Hebel and also into the outer flues.  
Enclosed cavities are not allowed if the combustible wall is removed and the unit is installed against or through the brick wall, ventilation holes can be left in the hearth between the brick walls and the unit. It is important for air to flow between the flues.
13. Insulation to wrap around the firebox where painted red.
14. Air intake – Do not obstruct.
15. Hearth (See diagram 1 Page 7 – Summary of minimum installation specs).
16. 12mm AC Sheet.
17. Timber floor.
18. Reinforced concrete footing-Generally not required with a Hebel installation.
19. Insulate between top of firebox and Hebel/brick with the insulation provided.
20. If rendering keep a 2mm expansion gap to flange.
21. For burning gas a ½ inch BSP inlet on RHS of firebox is required. Drill at 100mm from base and rear of firebox. Avoid penetrating the convection chamber located at the rear of the firebox.

# Summary Of Minimum Jetmaster Installation Specifications

## 1. Hearth

Autoclaved aerated lightweight concrete block, or for hearths 100mm thick FC Sheeting or any suitable non combustible material like slate, granite or marble is acceptable.

- Models 400-1500 must be minimum 100mm thick.

This includes selected finish such as ceramic tiles, marble or granite.

- Must project forward of aperture by a minimum of
 

440-700	=	300mm
850	=	400mm
1050	=	500mm
1200-1500	=	900mm

(see table on page 5 for larger sizes)

- Must project either side of aperture by a minimum of 200mm.

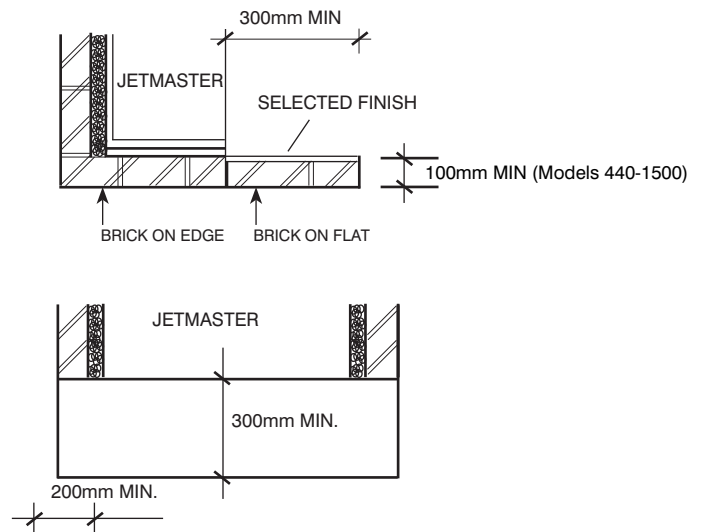

## 2. Flue

- Single skin flue (stainless steel) must be enclosed with single skin brickwork, concrete, or autoclaved aerated concrete block.
- Twin skin flues (stainless steel inner, and galvanised outer) can either be left exposed or enclosed with stud walls and sheet plaster or timber. A minimum of 50mm clearance must be maintained between the outer flue and any combustibles. If using double skin flues space inner and outer flues using 3x25mm self tapping screws through outer casing at bottom, at each joint and at top. Also ensure that flues are ventilated at top and bottom, and when using a cover cone drill a series of holes into the outer flue below the cover cone to ensure adequate ventilation.
- Fit cowl to flue or chimney breast.

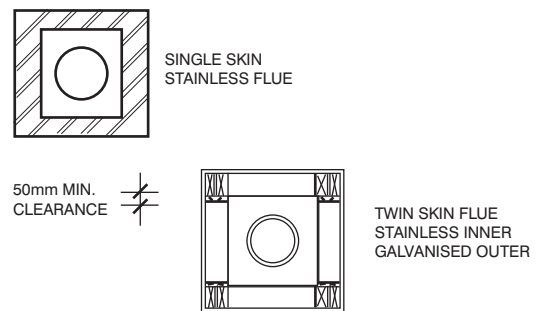

## 3. Enclosure

- A minimum of single skin brickwork, concrete, or autoclaved aerated concrete block must surround the firebox and gather at back, sides and front. A minimum of 25mm air gap filled with insulation material provided must be maintained.

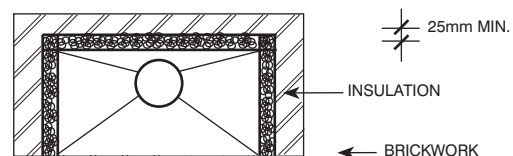



# Installation Instructions Full Brick Chimney

## ALTERNATIVE BRICK CHIMNEY TERMINATION

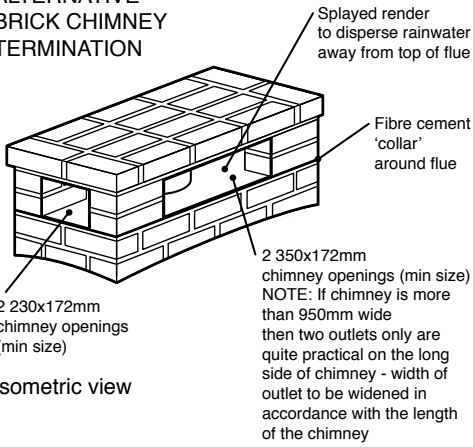

Isometric view

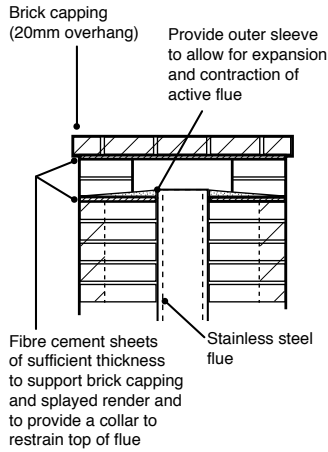

Section

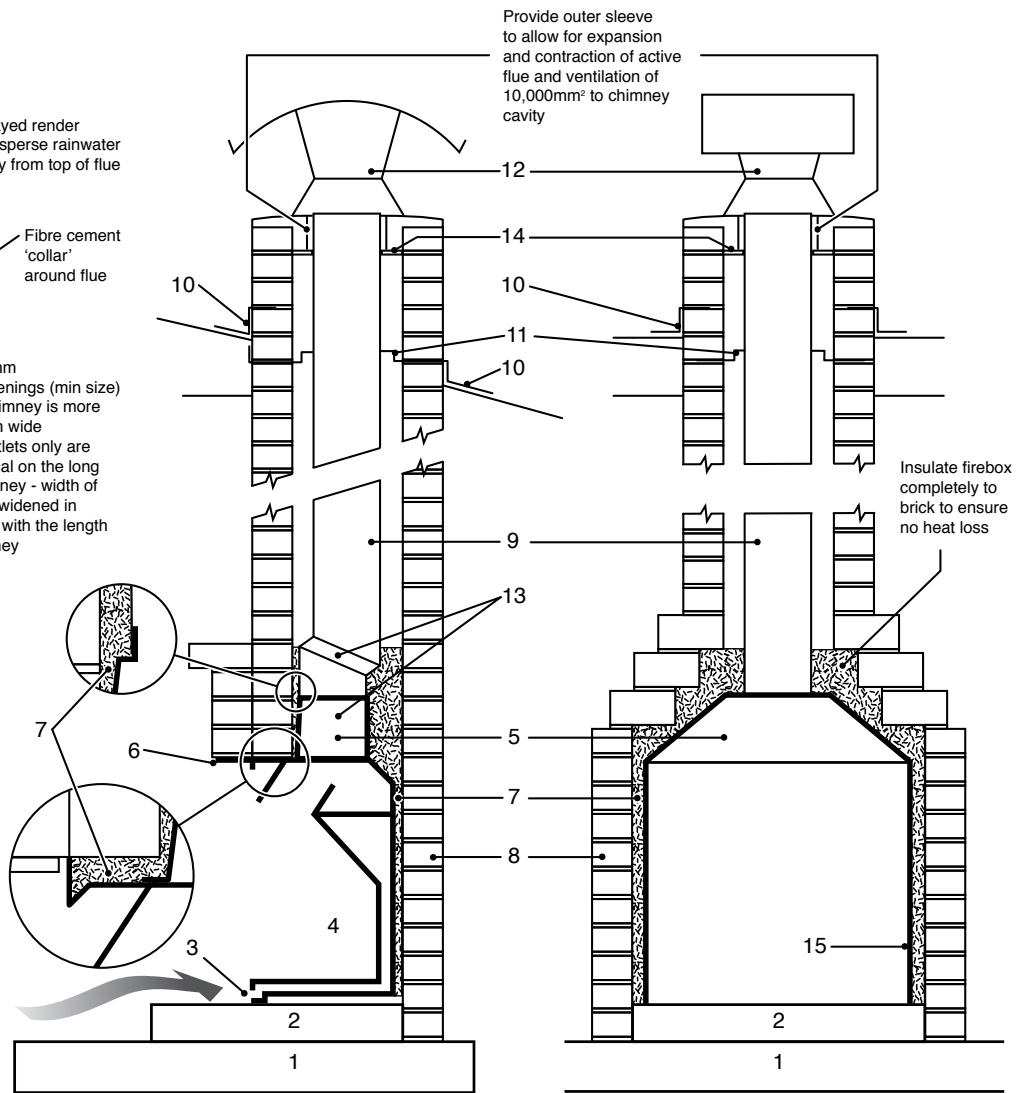

## Step by step check list

Warning! Please read these instructions carefully. Failure to adequately follow the instructions can result in serious injury or death.

1. Position firebox on a non-combustible hearth-see diagram 1 page 7 (summary of minimum installation specs.)
2. Bolt gather to firebox.
3. Insulate entire firebox and gather where painted red with the insulation provided.
4. If using a Jetmaster lintel, bolt lintel to firebox. If using an angle bar as a lintel you can use the side Hebel or brickwork to support the lintel - insulate between lintel and firebox. You can lay your Hebel or brickwork directly onto the top of the firebox between the gather and front flange of the firebox. However it is important to insulate between the brickwork and firebox. Also insulate between flue and brickwork.
5. Ensure air intake area at bottom of unit is not obstructed
6. Brick around firebox.
7. Do not recess the firebox by more than 110mm. A greater dimension could result in compromise in convected heat.
8. Rivet an inner active starter flue to gather with two female ends to allow second length to have crimp facing down. Rivet active flues together at crimped joins.  
Encase the flue with brickwork and it is suggested that a piece of 9mm fibre cement sheeting with a circular cut out to accommodate the flue be positioned on the chimney opening, one course of brickwork from the top of the chimney. Slope mortar outward from the flue which should protrude through the cement sheet by 50mm (see diagram page 7 alternative brick chimney termination).
9. Fit a recommended Jetmaster flue cowl to the top of chimney.
10. Gas burning - A ½ inch BSP inlet on right hand side is required. Drill at 100mm from base and rear of firebox from outside of firebox. Avoid penetrating the firebox from the rear.

## Installation with full brick chimney

1. Re-inforced concrete foundation.  
Suspended floors will require supports and footings.
2. Hearth.
3. Air inlet. DO NOT BLOCK.
4. Firebox.
5. Gather.
6. Optional lintel, as firebox supports brick wall. (If other than the Jetmaster lintel used, a 100 x 10 angle bar is needed and allow at least 2mm for expansion.
7. Insulation.
8. 115 minimum brickwork.
9. Gap between stainless steel flue and brickwork may (optional) be filled with mortar (8 sand, 3 lime, 1 cement).
10. Approved Flashing.
11. Drip tray.
12. Jetmaster stationary cowl, rotating cowl, (also see diagram alternative brick termination-this page) A.G.A. gas approved cowl when using gas.
13. Optional 45 degree bends or offset gather available.
14. Fibre cement sheet under last course of bricks with hole cut to restrain flue. Provide outer sleeve to allow for expansion and contraction of active flue and 10,000mm<sup>2</sup> ventilation to chimney cavity when filling space below cowl base with mortar.
15. For burning gas: 1/2-inch B.S.P. inlet on right hand side of firebox is recommended. Drill at 100mm from base and rear of the firebox measuring on outside of firebox.

## Important points

- Do not block air inlet. Cover all surfaces of fireplace, including, gather, with insulation provided.
- Build the brickwork at the back and sides of the fireplace against insulation. Seal any gaps between gather and firebox with the fire cement or insulation provided.

# Flue Heights & Flue Termination

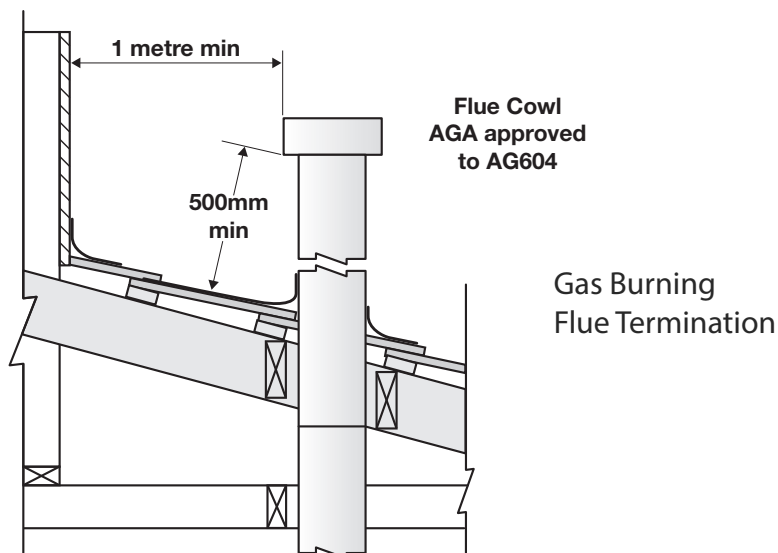
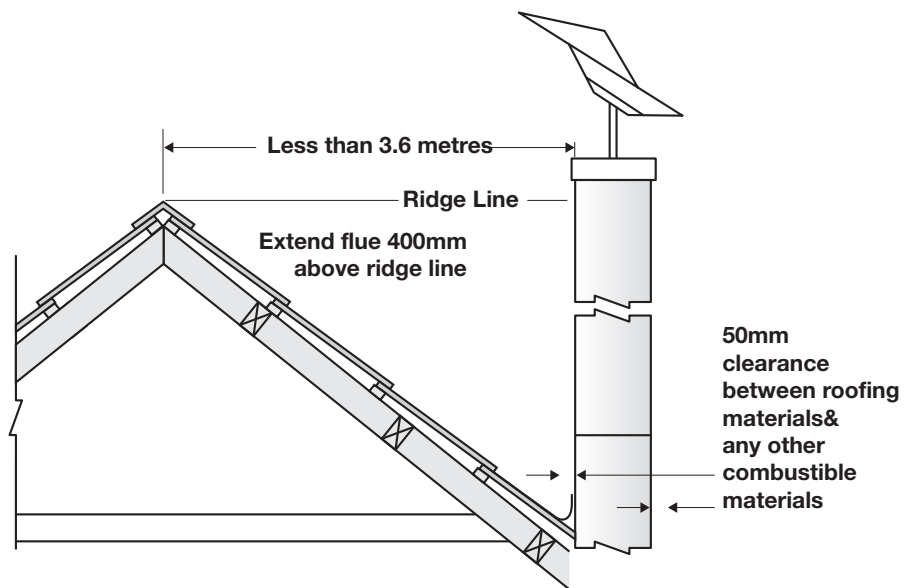
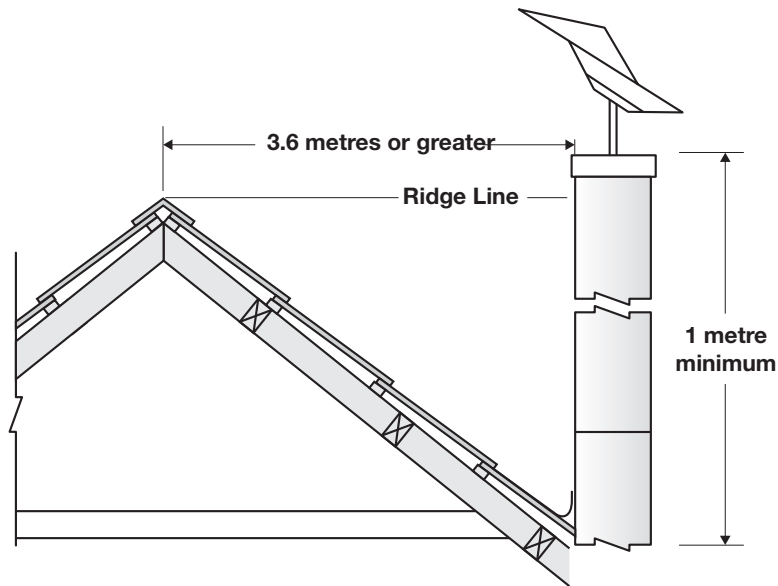

## Installation Into An Existing Fireplace

Please read these instructions before beginning

### Step by step checklist

1. Check the chimney for cracks, cavities and blockages and repair these. The size of the Jetmaster Firebox is determined by the minimum dimensions of the chimney flue.

Minimum flues areas are:

Model 500, 600, 700sh- 400 cm<sup>2</sup>

Model 700D, 850-450 cm<sup>2</sup>

Ensure that this area is maintained throughout the entire chimney.

Flues that are 10% smaller than this will work depending on the height of the chimney. Chimney pots that are too small should be removed. Stainless steel flues may be used if the chimney is in poor condition.

2. Measure the width, depth height of the recess. The following table lists the minimum dimensions of the recess for each unit.

UNIT SIZE	WIDTH	DEPTH	HEIGHT
500	570	350	640
600	670	350	640
600 Low	670	350	590
700SH	770	350	640
700 Low	770	350	590
700D	770	400	690
850	920	450	740
850 Low	920	450	690
1050	1100	500	790
1050 Low	1100	500	690

- Allow 25mm on each side of the firebox for insulation

#### A. Recess too large:

I) The recess can be reduced by inserting bricks or Hebel at the sides and/or back, and where necessary between the top of the unit and the underside of the lintel. The existing hearth can also be built up either with bricks or by forming a plinth.

II) Use Jetmaster fascias and trims to seals gaps less than 75mm between sides and top of the unit and masonry.

- B. Recess too small: The recess can be made deeper by removing the rollback and smoke shelf. If the height is too low, remove the lintel and replace at the required height. If the sides have to be removed it is suggested an experienced builder to do the work as the sides support inner flues of the chimney.

NOTE Allow 1mm expansion gap for all materials.

3. Repair any cracks or cavities in the recess especially if it has been chopped out to accommodate a specified unit size, and the cavity between a double brick wall has been exposed.

N.B. No metal gather is required. The Jetmaster is designed to operate in existing fireplaces without using the gather or metal flues.

4. Tape the insulation to back and sides of the Jetmaster and slide into position, taking care not to snag the fibreglass insulation against the sides.

#### The check:

A. Do not recess the unit by more than 110mm.

B. The two smoke outlets on the firebox marry up with the existing chimney. (There must be a 200mm minimum to any overhang above smoke outlets).

C. Do not obstruct air intake at the bottom of the unit.

5. At this stage block the gaps between the unit and recess with pieces of cardboard and have a test fire using paper only. If continuous smoking occurs, check size of chimney pots again. Also check for blockages in the chimney. "Downdraught" (wind blowing down the chimney is recognised by occasional puffs of smoke. In this case use Jetmaster rotating cowl. If smoking persists a smaller Jetmaster will have to be used.

6. Seal unit into position with the masonry, fascias or trims, ensuring any air leak around frame is limited. Allow masonry work to cure for a minimum of three days.

See next page for diagrams.

# Installation Into An Existing Fireplace

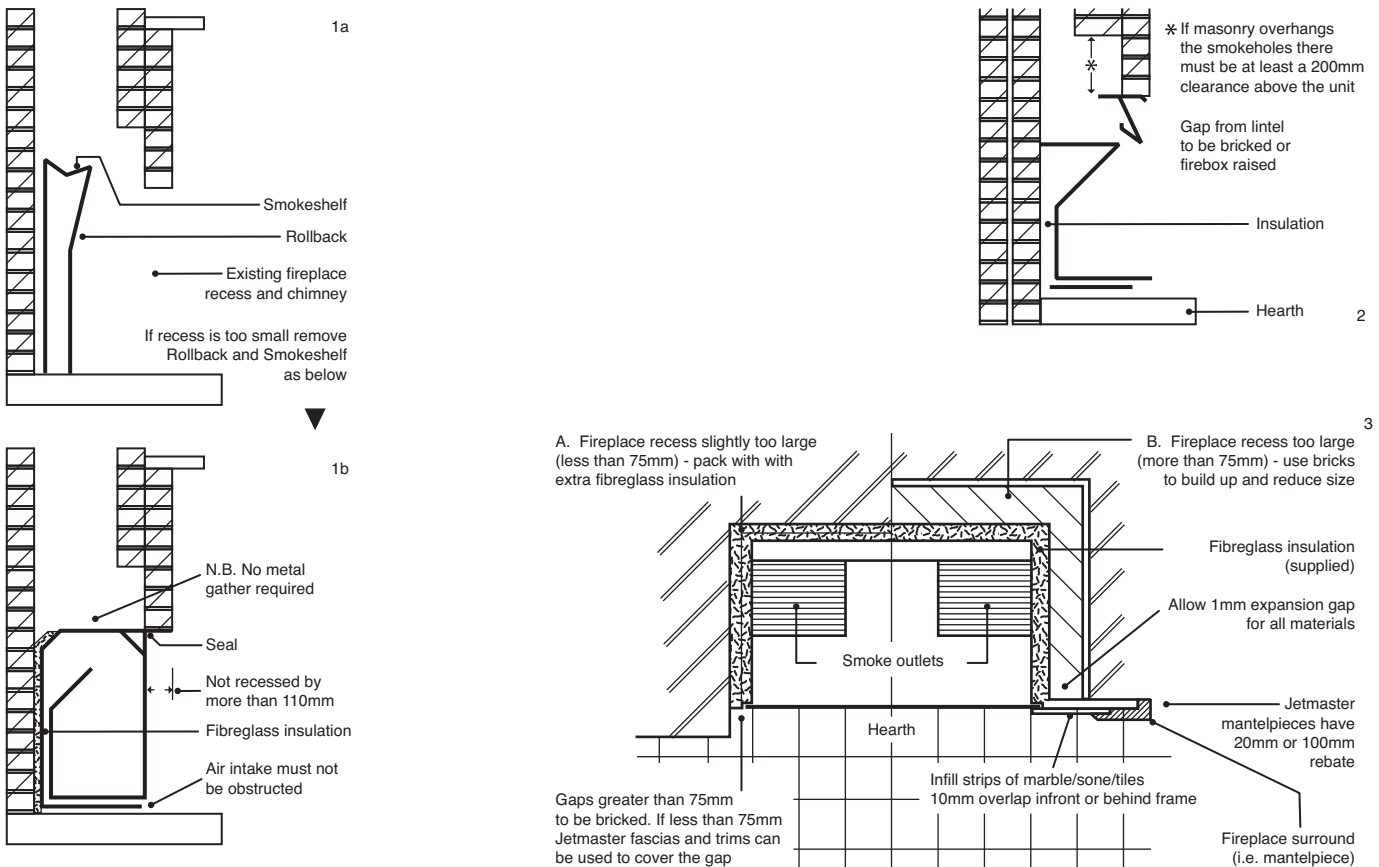

# Troubleshooting

1. Check that the gather is sealed to the firebox.
2. Check chimney. If chimney is closer than 3 meters to the apex of roof, the chimney should extend approximately 350mm past the apex. Chimney should be a minimum of 3.6 meters from the top of the gather.

Recommended flue sizes.

UNIT	FLUE SIZE	FLUE SIZE
	Round (diam. mm)	Square (mm)
500/600/700S	200	225x225
700 DEEP	225	250x250
850	250	250x250
1050	300	300x300

3. The cross section area of flue should be within 100% of the recommended size through its lengths and preferably straight. The angle of any bend should be more than 45 degrees. Chimney pots, which are too small to allow free flow, and mortar droppings at flue bends, are frequent causes of smoking.
4. Check smoke outlet. With the damper fully open, check for mortar dropping over the smoke outlet. Such mortar can be removed with a long cold chisel.
5. Check 'False' drafts entering around side of firebox / fascia / mantelpiece into cavity. Use fibreglass wool to prevent air movement.
6. Check air intake is not obstructed.
7. Check damper properly located on pivot-pins.

## Trims

1. Score the back of the stainless steel or mild steel trim and the surface to which the trim will be attached, to allow the two surfaces to adhere well to each other.
2. Place a bead of Silicone onto the back of the stainless steel trim.
3. Place another bead of Liquid Nails around the outer edge of the frame. This will cure quickly and hold the frame into position.
4. Clamp the trim onto the unit for 24 hours until the adhesives have cured

Attach trim to flange of firebox with heat resistant silicon (roof and gutter silicon is recommended)

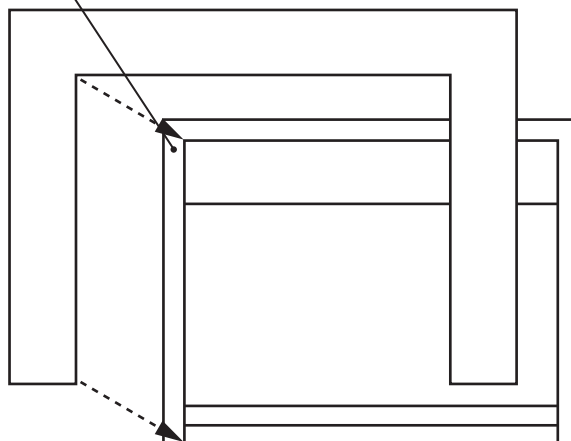

## Attaching Fascias

Use masonry plugs and drill through corners of fascia and attach to bricks or masonry.

If attaching to plasterboard use suitable toggles. If neither of the above is suitable, then use heat resistant bonding silicon.

N.B. Mantelpiece will hold fascia in position.

It may be necessary to leave fascia up to 10mm out of cavity to allow for flush fitting with mantelpiece. Use fibreglass wool to block gaps between fascia and cavity surrounds.

Cast iron fascias can be bolted and fixed to the plasterboard or brickwork behind firebox

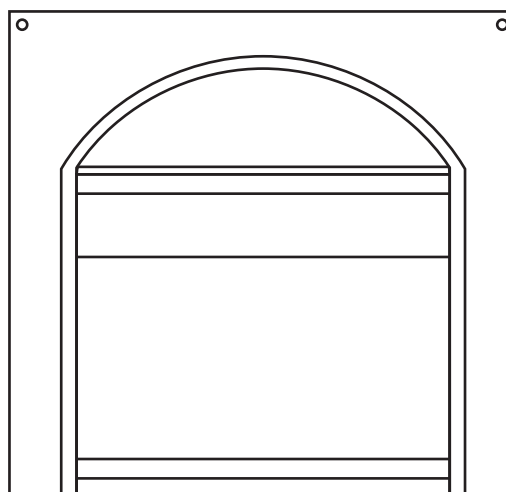

## Fitting Screens

Clip on Screens

For standard flange, square fascias and trims (Hang flush with opening. Locate lugs between flange and louvre).

## Attaching Mantelpieces

If fascia fits flush with wall no rebate on mantelpiece is necessary.

If fascia sits proud of wall, a rebate on mantelpiece is necessary. Most Jetmaster mantelpieces come with a 20mm rebate.

When mounting a mantel-piece, use mirror hooks or other suitable fixing brackets.

## How to use the wood fireplace

Your Jetmaster fireplace is designed not to smoke and by following a few instructions you will achieve optimum heat output, convenience and fuel economy.

Please note that the first fire could result in a few odours coming from the firebox. Do not be alarmed. This is not unusual when first using a metal finished product and will soon cease.

## Lighting a fire

1. Using a number of crumpled sheets of newspaper, some kindling and a few small split logs arrange your fire in a "Tepee tent" style.
2. With the tool provided, fully open the DAMPER by pulling the control lever towards you. (Not always applicable with Double Sided Firebox.)
3. Light the fire at both ends as well as at the centre.
4. When the kindling and small split logs are burning well, start to build up your fire with larger split logs.
5. When the fire is well established you can start closing the Damper. The amount you can close it will depend on the type of wood used and the general weather conditions. Experience will soon show you how far; however, the damper should never be closed more than half way.
6. When the fire has gone out completely, you can close the Damper fully thus preventing any loss of heat from the room up the chimney.

## Cleaning

1. The Jetmaster Log Pan is designed to give greater heat and fuel efficiency. For the duration of the cold season the Log Pan should never be emptied. The resulting bed of ash and coals from previous fires will soon become a heat bank generating more heat than the burning logs. This ash bed also insulates and greatly extends the life of the Log Pan. This is why an ash bed must be maintained at all times. When the level of the ash bed becomes too high, the top layer can be removed. Depending on frequency of use and quality of wood, this skimming procedure should not be required more than once or twice a Season!
2. To prevent chimney fires as well as enabling the chimney to draw properly, the chimney/flue should be swept at least once a season, subject to the quality of timber used in the fire.

## General Maintenance

The visible parts of your Jetmaster can be cleaned with a damp cloth or soft brush. Should you wish you could repaint the unit with a heat resistant paint?

## Safety

The Jetmaster is a safety-tested unit. However, you must never leave an open fire unguarded. Jetmaster has a screen that is designed to prevent sparks leaving the fireplace and very resistant to being accidentally knocked over by young children.

## Fuels

1. Medium density woods are preferred for open fireplaces. Softer woods (Pines etc) burn fast, leaving a lot of ash and creosote. Hard woods (Red Gum etc) can be best used when mixed with medium woods and should not be used to start a fire.
2. A split log will burn better than a full log.
3. Wood should be stored (seasoned) in a dry ventilated area for at least 12 months. "Green" wood can have 50% moisture, which results in a very poor heat emission. Box woods (e.g. Grey Box and Yellow Box) are highly recommended as they produce fine coals. Burning well seasoned medium density wood is the most important step towards achieving optimum results from your Jetmaster!

## Gas Fires

See separate installation manual with gas burner.

